

**Ranch Pro Service Kit Parts - Shown Approximate Actual Size\***  
 PLEASE CALL RHINO IF YOU DO NOT HAVE ALL THESE PARTS IN YOUR KIT BAG  
 (# location indicated on exploded parts diagram)



\*This is a quick reference guide to your sizes, they are as accurate as possible allowing for some variances.

**RHINO TOOL COMPANY, INC.**  
 P.O. Box 111 | Kewanee, IL 61443

Please visit:  
[www.rhinotool.com](http://www.rhinotool.com) to find your nearest servicing Rhino Dealer

300816.03.21.18



## Rhino® Ranch Pro™ Service Kit Installation

### Rhino® Ranch Pro™ Standard Configuration

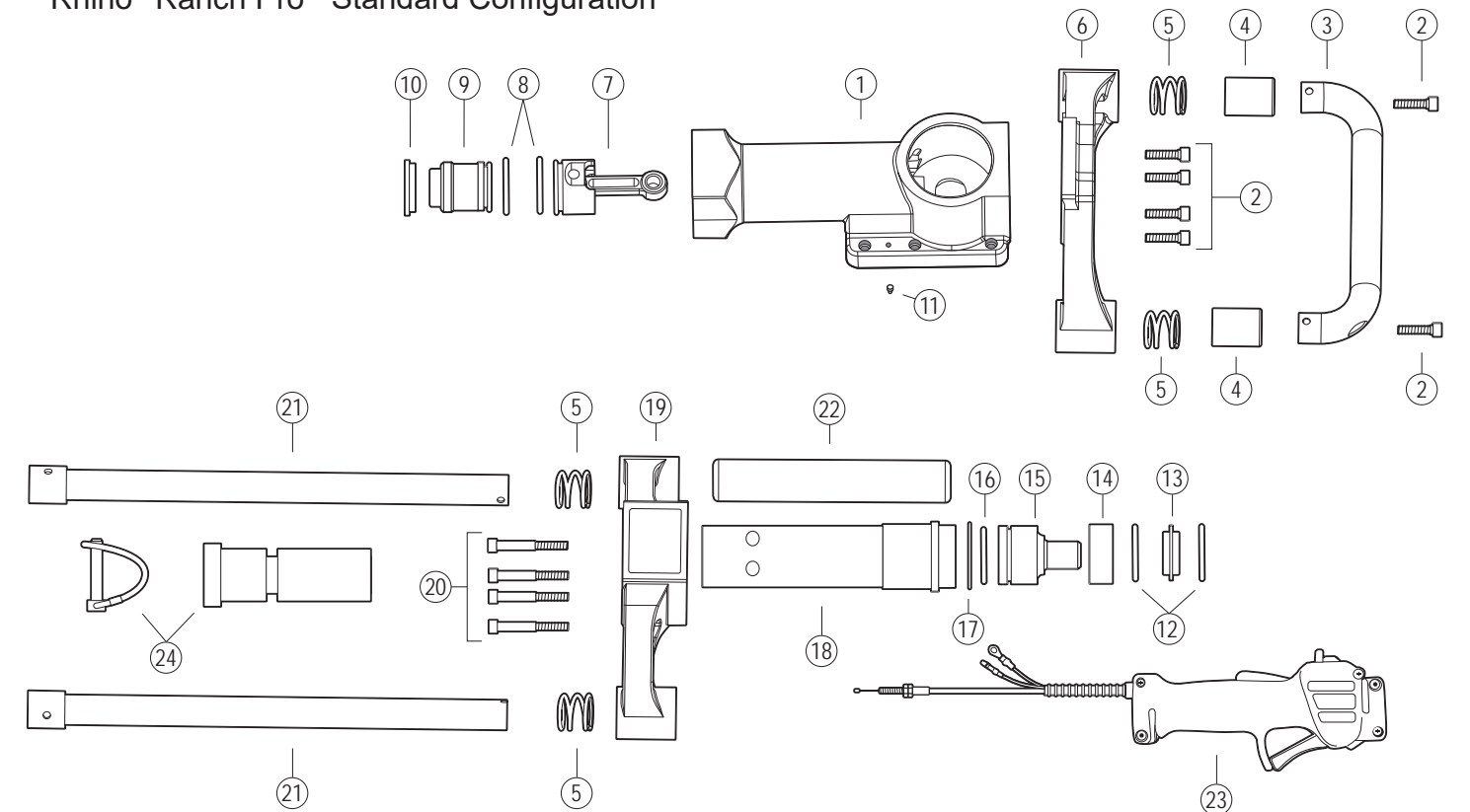

1: Loosen the two 5/32" bolts on the Throttle (#23). Do Not Remove Them.

2: Mark the top side of the Handle Collars (#4) with a black marker or alike as they are specific on the direction they are installed. Using a 1/4" Hex Wrench, remove the two 5/16" bolts (#2) recessed in the Top Handle Assembly (#3). **Caution as the Handle Collars (#4) are under tension from the Handle Springs (#5).** Set aside.

3: Using a 1/4" Hex Wrench, remove the four 5/16" bolts (#20) from the lower body (#19). Take down the Lower Body with both Side Handles (#21). Remove the Throttle (#23) from the Side Handle.

4: Discard the used Chuck Tube O-Ring (#17).

5: Extract the Anvil O-ring Cup (#14) and its components; Large Retainer (#13) and Large Retainer O-rings (#12) from the Chuck Tube (#18). Inspect for damage. Discard Large Retainer O-rings.

6: Remove the Anvil (#15) from the Chuck Tube(#18). Inspect for damage. Remove the Anvil O-ring (#16) and discard. Lubricate the Anvil's O-ring groove with the lubricant supplied with the kit and install the new Anvil O-ring, reseal the Anvil into the Chuck Tube.



# Rhino® Ranch Pro™ Service Kit Installation

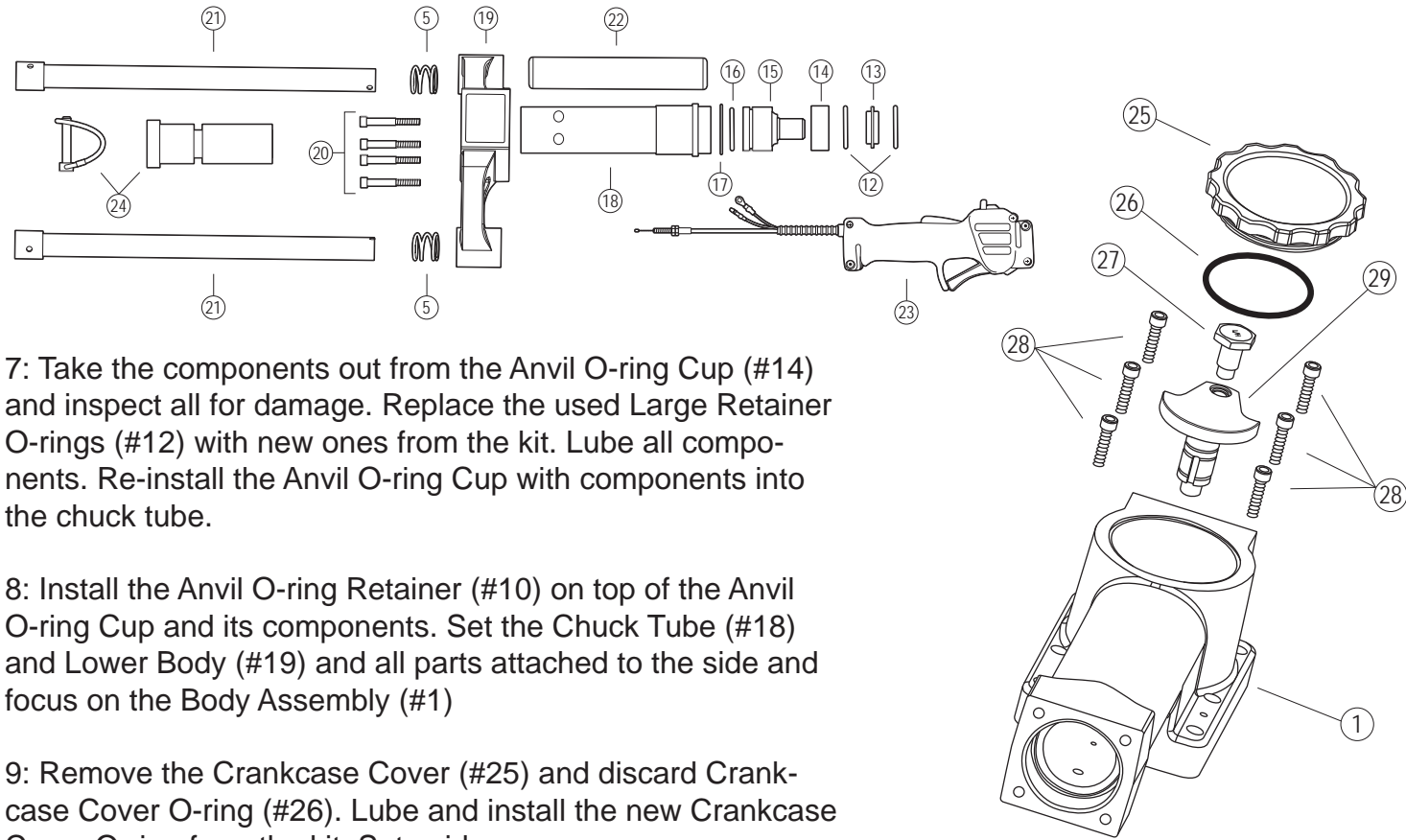

7: Take the components out from the Anvil O-ring Cup (#14) and inspect all for damage. Replace the used Large Retainer O-rings (#12) with new ones from the kit. Lube all components. Re-install the Anvil O-ring Cup with components into the chuck tube.

8: Install the Anvil O-ring Retainer (#10) on top of the Anvil O-ring Cup and its components. Set the Chuck Tube (#18) and Lower Body (#19) and all parts attached to the side and focus on the Body Assembly (#1)

9: Remove the Crankcase Cover (#25) and discard Crankcase Cover O-ring (#26). Lube and install the new Crankcase Cover O-ring from the kit. Set aside.

10: With a black marker, or alike, mark the Piston Assembly (#7) to re-install it in the same orientation when reassembling. Note that the Crank Pin (#27) is left hand thread. Use a 7/8 deep-well socket to remove the Crank Pin. Inspect the Crank Pin and threads for damage as well as the Crank Shaft (#29) threads. Extract the Piston Assembly and Hammer (#9) from the Body Assembly (#1) and remove the O-rings and discard. Inspect the Self Lubricating Bronze Sleeve Bearing in the Connecting Rod of the Piston Assembly and check either for wear or out of roundness. Piston Assembly is only available as a complete assembly. Lube the Hammer and Piston Assembly O-ring groove and install one of the Piston/Hammer O-rings (#8) from the kit on each. Set aside.

11: Clean all lubricant from the Crank Pin (#27) and lay on a shop towel along with the four Lower Body Bolts (#20) and two Handle Bolts (#2). Including the Crankshaft (#29) and Side Handle Assembly's (#21) spray all threads with Loctite N 7649 Primer and let dry.

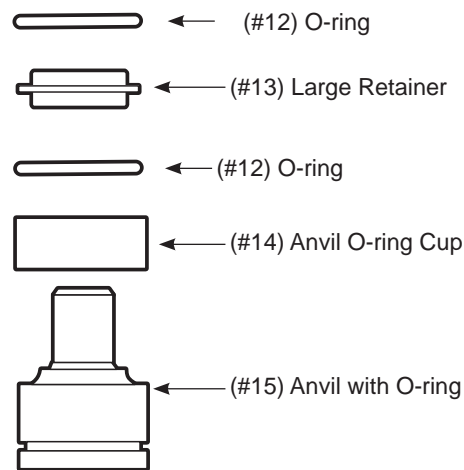

Insert O-ring into Anvil O-ring Cup, then insert Large Retainer (with large radius at bottom towards the anvil), then insert other O-ring.



# Rhino® Ranch Pro™ Service Kit Installation

12: Clean out all lubricant from the Body Assembly (#1). Install Piston Assembly (#7) with the connecting rod facing the top of the driver and mark made in Step 10 facing outward. Locate the Self Lubricating Bronze Sleeve Bearing in the Connecting Rod of the Piston Assembly and align it with the threads in the Crank Shaft (#29). Apply Loctite 243 Threadlocker to the Crank Pin Threads and install it through the connecting rod of the piston assembly. Crank Pin has left hand threads. Torque to 360 in/lbs. Install Hammer (#9) with the Hammer O-ring (#8) towards the top of the driver.

13: Obtain the Lower Body with chuck tube from Step 7. Place the Chuck Tube O-ring (#17) on top. Apply Loctite 243 Threadlocker to the four Lower Body Bolts (#20). Install the Throttle (#23) on the Side Handle Assembly (#21). Install the Lower Body Assembly on the Body Assembly (#1) and torque to 251 in/lbs. Place the top of both side handle assemblies (#21) through the top handle bracket (#6) and slide the throttle to its lowest point and tighten the upper 5/32" HEX bolt used to hold the Handles in their most up position. Make sure the handle springs (#5) are installed in the top handle bracket.

14: Install the handle collars (#4) with the mark made in Step 4 in the up position. Insert both handle bolts (#2) into the Top Handle Assembly (#3) so that the threads are exposed. Apply Loctite 243 Threadlocker to the bolt threads and install the Top Handle Assembly on to the Handle Collars. Apply downward force to compress the Handle Springs (#5) and torque the Handle Bolts to 132in/lbs.

15: Fill the crankcase with one tub of lubricant from the kit. With a 7/8" Deep-well Socket spin the Crank Pin (#27) counter-clockwise feeling for any binding on the Piston Assembly (#7). Locate Crankcase Cover (#25) with Crankcase Cover O-ring (#26) from Step 7 and install. **Hand tighten only.**



Ranch Pro Service Kit Part No. 300508:  
(# location indicated on exploded parts diagram)  
(#8) O-Ring Seal for Piston and Hammer - P/N: 300600 (Qty. 2)  
(#26) O-Ring Seal for Pro-Series Crankcase Cover - P/N: 301617  
(#12) Large Retainer O-Ring Seal - P/N: 300604 (Qty. 2)  
(#16) Anvil O-Ring Seal - P/N: 300606  
(#17) Chuck Tube or Sleeve O-Ring Seal - P/N: 300608  
Rhino Pro-Series Lubricant - P/N: 300500

For more information on installing the Ranch Pro Service Kit, visit [www.rhinotool.com](http://www.rhinotool.com).