

Operating Manual

Rhino® **HPD 60** **Hydraulic** **Post Driver**

Revised 04.2020

Prior to Operation

We thank you for choosing a Rhino® Hydraulic Post Driver.

To ensure smooth operation and long-lasting performance of your new post driver, we recommend you study this operation manual carefully and pay special attention to the chapters about

Safety and Service Precautions

and

Oil Flow and Pressure

We hope you will be satisfied with your new Rhino® Hydraulic Post Driver.

Best Regards,
Rhino Tool Co.

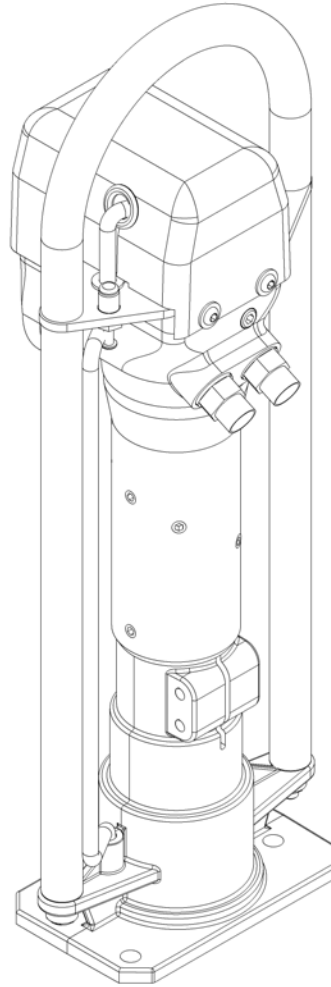

Rhino Tool Co. Inc.
1134 West South St.
Kewanee, IL 61443

Tel: 309.853.5555 main
Tel: 866.707.1808 toll-free
Fax: 309.856.5905
info@rhinotool.com
www.rhinotool.com

Contents

	Page
Safety Precautions.....	2
Oil Flow and Pressure	4
Vibration Level	4
Starting Instructions	5
Technical Data	7
Performance Chart	8
Connection to Hydraulic Power Sources.....	9
Service and Maintenance	9
Trouble Shooting.....	10
Oil Types	11
Warranty Terms.....	12
Spare Parts List	13

Safety Precautions

- Only use the post driver in accordance with the local working regulations on allowed working time based on post driver vibration level. Working with the post driver longer than prescribed may injure the operator. Please refer to the chapter about vibrations, page 4.
- A fine jet of oil at pressure can penetrate the skin. It is therefore important never to use your fingers to check for oil leaks and never to hold your face close to suspected leaks – use a piece of cardboard instead. If oil has penetrated the skin, you should get medical treatment immediately.
- Never leave the post driver when connected to the powerpack.
- Always use correct adaptor when driving a post into ground.
- Before connecting the post driver to the power source, always check that the chuck and adaptor are firmly secured in order to prevent damaging post and injuring operator.
- Always use approved hoses. Contact your dealer, if necessary. Mount the hoses correctly – the valve housing is marked with "P" and "T".
- The operator must make sure that there are no persons nearby when he starts using the post driver.
- The operator must pay extra attention and show caution when working in difficult working areas, such as slopes and other dangerous nature of the ground. Do not reach too far with the post driver, and always maintain a good footing and keep your balance.
- The operator must be properly trained in using the post driver or under supervision of a qualified instructor.
- The operator must always use protective goggles, earplugs, hard hat, gloves and shoes when operating the post driver.
- Prior to operation, call a utility service to check whether there are hidden or buried cables in the ground.
- Never wear loose clothing as it may get entangled in the moving parts of the post driver.
- Inspection or cleaning of the post driver, change of adaptor or disconnection of hoses must never be done while the post driver is connected to a running powerpack, as unintentional activation of the post driver can cause severe damage.
- Always connect hoses to the post driver before starting the powerpack. Be sure that all couplings are tight.
- The post driver may not be operated if the oil temperature is above 158°F(170 C°). Operation at higher temperatures may result in the post driver getting warmer than normal, and putting the operator at risk of being burned.
- To avoid personal injury and damage to material, all repair, maintenance and service work must be carried out by authorized and properly trained persons only.

IMPORTANT

- When storing a post driver it should always be kept in a safe and dry place.
- Try not to do a job with a post driver which is too small for the job.
- Keep the chuck and adaptor in good condition for maximum driving performance.
- The post driver may never be operated without a chuck, or without being held against the pole end, as this may result in overload of the post driver.
- Always make sure that the post driver labels and warning signs are legible.
- Always use hoses, couplings and spares as such recommended for the Rhino® Hydraulic Post Driver.
- All repair, maintenance and service work must be carried out by authorized and properly trained persons only.
- Make sure that all couplings are cleaned before connection.
- Always disconnect the hydraulic circuit before connecting or disconnecting the post driver. If this is not done, there is a risk of damage to the quick release couplings or the hydraulic system getting overheated.

Oil Flow and Pressure

Your new Rhino® Hydraulic Post Driver is designed for a certain oil flow, working pressure and maximum pressure. A too high oil flow and/or a too high pressure results in overload of the post driver, meaning that the lifetime of your new Rhino® Hydraulic Post Driver will not be as expected, and that your service and repair costs will be too high.

It is important to check that the post driver is not supplied with an oil flow beyond its design capacity, that the working pressure is correct and that the maximum allowed pressure is not exceeded.

On page 7 you will find a complete survey of the technical data, and on page 9 there is a guide to connection to hydraulic power sources and how to ensure that the post driver is not overloaded.

Vibration Level

There are many examinations about the risk of contracting the so-called “white fingers” disease as a consequence of the use of tools with high vibration level.

To reduce the risk of injury, a number of guidelines for maximum daily use have been laid down. The risk is minimized if you stay below maximum of daily use.

It is therefore important to manufacturers of handheld post drivers that they offer post drivers with a low vibration level.

At Rhino Tool Co., we anticipate the safety of our customers by maintaining very low vibration levels, whenever possible, in our products.

Starting Instructions

START – NO REMOTE

- Mount chuck and adaptor (if required) designed for the post
- Connect hoses – clean couplings before connection
- Set the power source on "ON"
- Slide the post into the driver as shown in Fig. 1
- Lift the post and driver to a vertical position as shown in Fig. 2
- Press the trigger lever towards the handle

START – WITH REMOTE

- Mount chuck and adaptor (if required) designed for the post
- Connect hoses – clean couplings before connection
- Set the power source on "ON"
- Slide the post into the driver as shown in fig. 1

Fig. 1

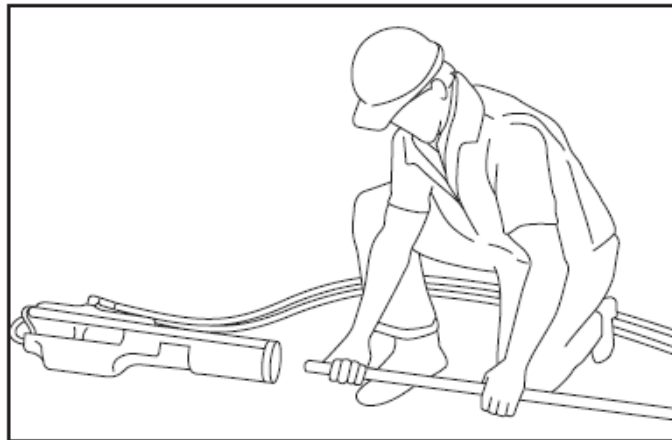

- Lift the post and driver to a vertical position as shown in fig. 2

Fig. 2

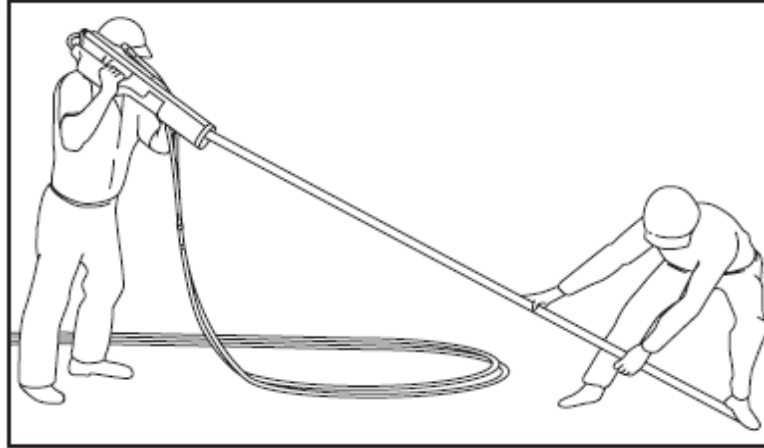

- To start the post driver move the control valve to the ON-position. Fig 3

Fig. 3

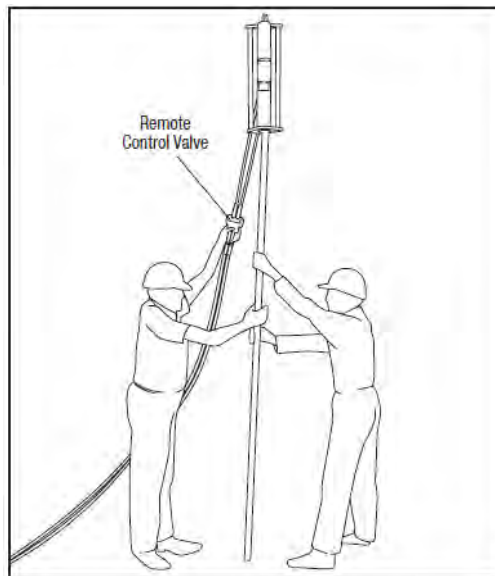

STOP

- Let go of the trigger lever or move the control valve to OFF-position
- Turn off the hydraulic oil flow before disconnecting the post driver

Technical Data

		Post Driver
		8 g.p.m. (30 l.p.m.)
Weight Post Driver		64 lb. (29 kg.)
Service weight incl. adaptor and hoses		68.5 lb. 31 kg.
EHTMA category		D
Oil flow		8 g.p.m. (30 l.p.m.)
Working pressure		1725 psi (120 Bar)
Max. setting pressure relief valve		2300 psi (160 Bar)
Max. return pressure		220 psi (15 Bar)
Blow frequency	1/min.	1380
Blow energy	Joule	95
Max. oil temperature	C°	158°F 70°C
Accumulator charging pressure		730 psi (50 Bar)
Cooling capacity needed	kW	3
Vibration level 3 axis (ISO 20643)	m/s ² (dB)	9.4 (139)
Uncertainty (K)	m/s ² (dB)	1.4 (123)
Sound pressure level (L_{PA}) 1 m	dB	96
Sound power level (L_{WA}) guaranteed	dB	108
Chuck size		Depending on post
Largest chuck possible		Max. 3 3/4" (ø95 mm)
Round		Max. 2 5/8" x 2 5/8"
Square		(67x67 mm)
Hexagon		Max. 3 1/4" (82 mm)

Performance Chart

Rhino® Hydraulic Post Driver Maximum length of different size hoses.

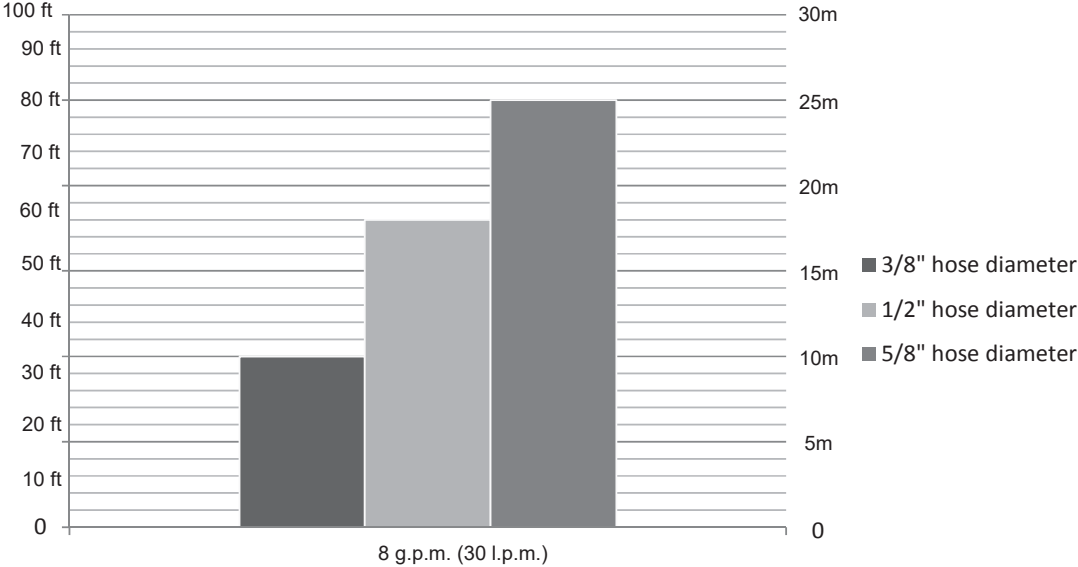

Pressure from power pack: 150 bar., Flow: 8 g.p.m. (30 l.p.m.), zero elevation,
2 set couplings per 33 ft. (10 m) hose.

Connection to Hydraulic Power Sources

The post driver can be connected to various hydraulic power sources, such as excavators, trucks, loaders, tractors etc., and of course Rhino® Power Packs, the design of which ensures your new Rhino® Post Driver the absolute best working conditions.

It is important that the post driver is not subjected to an oil flow and a working pressure beyond its design capability. Please refer to the ID-tag on the post driver in case of doubt. Check the oil flow and the working pressure by means of test equipment. The test equipment should comprise a pressure gauge, a flow meter and a valve for adjustment of the pressure.

Make sure that:

- the oil flow is not too high
- the working pressure is not too high
- the return pressure is not too high
- the pressure relief valve is not set higher than 2320 psi (160 bar)
- the internal diameter of the hoses is sufficient (min. ½")
- all couplings are clean
- the power source is equipped with an oil filter of min. 25 Micron

Hoses with too small internal diameter and/or defect couplings cause the post driver to work with incorrect working pressure. Your dealer can help you check this.

If the output of the power source is too high:

- the power source must be adjusted to correct output
- or you can choose to mount a Rhino® Post Driver oil flow divider to protect the post driver against overload
- or you can choose one of our Rhino® Power Packs. Your dealer can guide you in choosing the right power pack.

In case of doubt, please contact your dealer or a Rhino Tool Co. Representative

Service and Maintenance

Service/Maintenance	Daily	Weekly	Yearly
Check couplings and clean carefully	X		
Check hoses	X		
Check accumulator			X

NB. At service/repair it is important to mount the hoses correctly. The feed line from the power source must be mounted at "P" and the return line at "T". "P" and "T" are marked on the valve housing.

Trouble Shooting

If your driver is not operating correctly, first check that the oil flow from the power source is correct and that the pressure relief valve is set correctly. Follow the instructions in the owners manual of the power source.

Problem	Cause	Solution
Post driver does not start, there is <i>no</i> pressure in P-hose	Trigger mechanism does not actuate trigger piston correctly	Dismount top cover, and check and adjust functioning.
Post driver does not start, there <i>is</i> pressure in P-hose	Striking piston is stuck in cylinder	Nose part is tightened too hard. Seizing between cylinder and striking piston. Polish or replace components.
	Defective Q.R. coupling	Check Q.R. coupling
	Oil supply is made to T-connection	Switch Pump and Tank line
Chuck does not fit around the post during operation	Chuck is damaged	Replace parts.
	Wrong chuck size	Replace chuck to right size.
Post driver works irregularly	Impurities in hydraulic oil	Replace *oil and *oil filter
	Oil level in power source too low	Add hydraulic oil
	Wrong chuck size or worn out anvil	Check
Bad performance	Internal leak	Dismount valve housing and replace O-rings.
	Oil flow from the power source is not correct for the post driver	Check oil flow
	Accumulator pressure too low	Charge with Nitrogen.
	Defective diaphragm	Replace diaphragm
	Defective Q.R. coupling	Check Q.R. coupling
	Return pressure too high	Check power source/hoses
	Hose diameter too small	Check hoses

*Hydraulic Oil

Oil Types

The Rhino® Hydraulic Post Driver uses standard hydraulic oil, i.e. all types of mineral oil and biodegradable oil, which comply with the following values:

Recommended viscosity	20-40 cSt
Permitted viscosity	15-1000 cSt
Viscosity index	Min. 100
Temperature area	-4° to 158° F (-20° to +70°C)

If using biodegradable oil, we recommend the use of Rapeseed Oil. Other types of oil may be incompatible with the seals. If you are in doubt, please ask your dealer.



General Warranty Conditions & Limitations on Liability

Rhino Tool Company, Inc. ("Rhino") warrants to the original purchaser, purchasing the Equipment in new condition, in original packaging from an authorized dealer that its Hydraulic Tool(s) will be free from defects in workmanship and materials (the "Limited Warranty"). The Limited Warranty shall survive for twelve (12) months with regard to all other components, excluding the Honda 13 HP engine and Vanguard 18 HP engine for which Rhino provides no warranty and for which the warranty is provided by American Honda Motor Co., Inc and by Briggs and Stratton Corporation respectively and the shall be the sole warranty applicable thereto. This Limited Warranty is non-transferable.

In the event of a warranty claim, the Hydraulic Tool(s) must be returned freight prepaid to Rhino or delivered in person to a Registered Rhino Servicing Dealer within the applicable warranty period with proof of original purchase provided. Rhino's obligation under this Limited Warranty is expressly limited to the repair or replacement, at Rhino's election, of such defective Hydraulic Tool(s), which is proved to be defective upon inspection by a Rhino-certified/authorized technician.

This Limited Warranty does not extend to a Hydraulic Tool(s) which has been subject to misuse, neglect, or accident, nor does it extend to any Hydraulic Tool(s) which has been repaired, altered, or serviced by unauthorized persons. This Limited Warranty does not cover any damage or adjustments required to any Hydraulic Tool(s) if such damage or adjustment is caused by the use of supplies, parts, or attachments not sold or approved by Rhino.

EXCEPT AS OTHERWISE PROVIDED HEREIN, RHINO DISCLAIMS ALL OTHER WARRANTIES, EXPRESS OR IMPLIED, INCLUDING, BUT NOT LIMITED TO THE IMPLIED WARRANTIES OF MERCHANTABILITY AND FITNESS FOR A PARTICULAR PURPOSE. UNDER NO CIRCUMSTANCES SHALL RHINO BE LIABLE FOR ANY LOSS OF BUSINESS, REVENUES, OR PROFIT OR OTHER INDIRECT, INCIDENTAL, SPECIAL OR CONSEQUENTIAL DAMAGES OR LOSS ARISING OUT OF ANY DEFECTS IN OR PERFORMANCE OF THE HYDRAULIC TOOL(S), HOWSOEVER CAUSED.

HPD-60 Post Driver spare parts list

From Serial No. 13110

Fig. 1

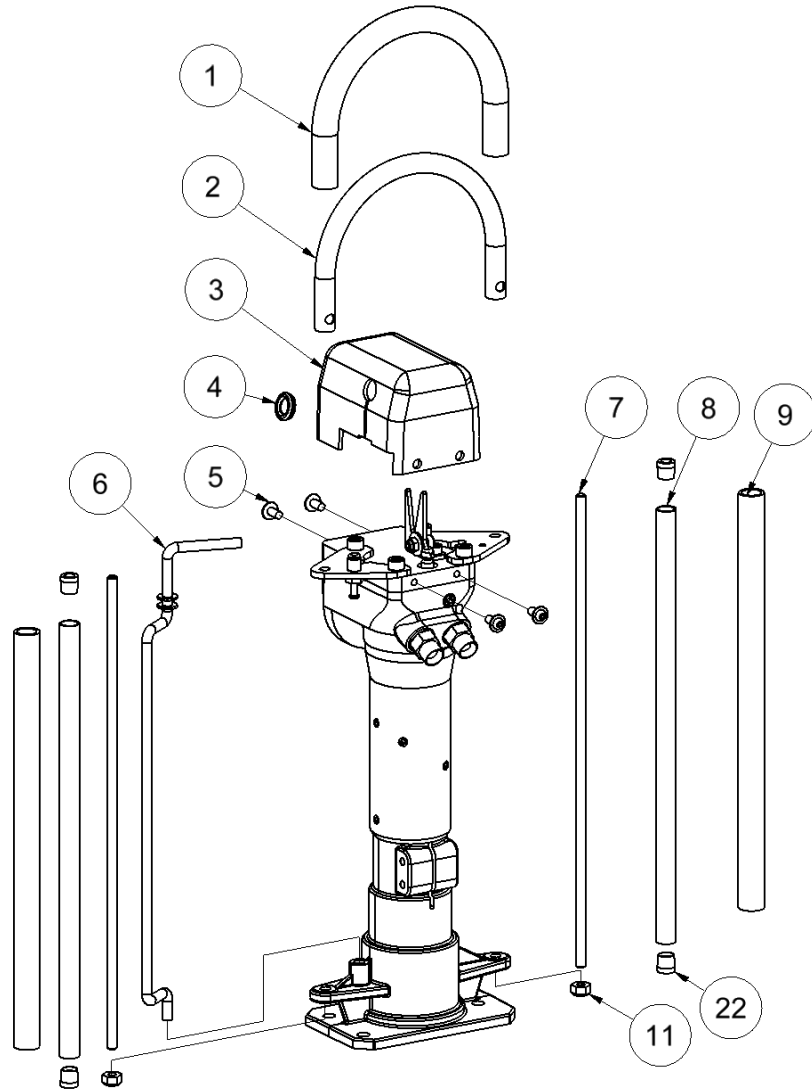

Pos.	Part No.	Description	Pcs.
1	RT7731447	Handle cover <i>Incl. in part No. 9012564 - not sold separately</i>	
2	RT9012564	Top handle	1
3	RT8712573	Top cover	1
4	RT7722412	Rubber grommet	1
5	RT7611282	Screw M8x16	4
6	RT8212731	Trigger lever	1
7	RT8612728	Threaded rod <i>Loctite 638</i>	2
8	RT9012730	Handle (435.5 mm)	2
9	RT7731447	Handle cover <i>Incl. In part No. 9012730 - not sold separately</i>	
11	RT7621027	Nut M10	2
22	RT8212589	Guide bushing <i>Incl. In part No. 9012730</i>	4

HPD-60 spare parts list

Fig. 2

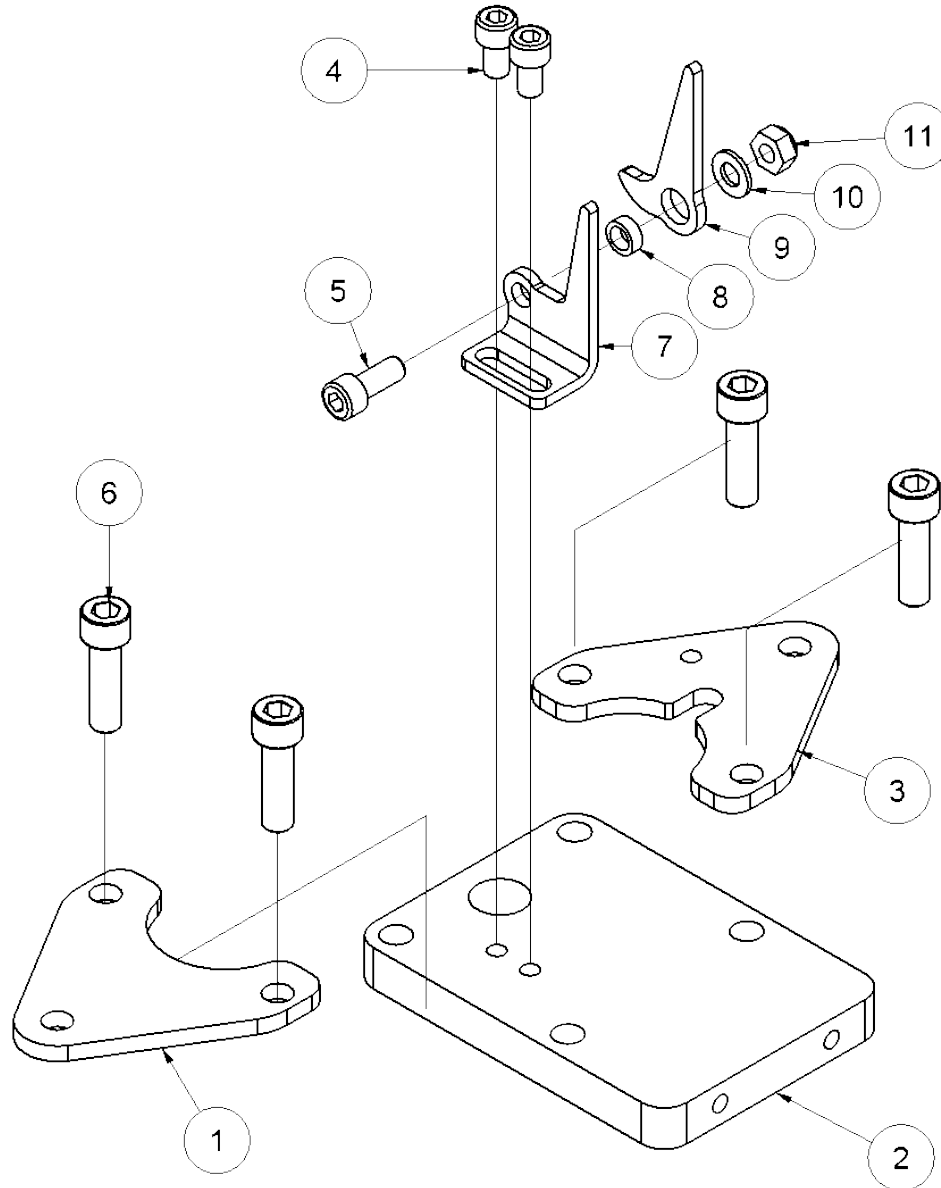

Pos.	Part No.	Description	Pcs.
1	RT8212588	Handle plate left	1
2	RT8212557	Top plate	1
3	RT8212566	Handle plate right	1
4	RT7631395	Screw Loctite 243	2
5	RT7611634	Screw	1
6	RT7612558	Screw Loctite 243 - 60 ft/lbs	4
7	RT8212559	Trigger bracket	1
8	RT8212561	Distance bushing	1
9	RT8212560	Trigger plate	1
10	RT7621171	Washer	1
11	RT7621010	Lock nut	1

HPD Post Driver spare parts list

From Serial No. 13110

Fig. 3

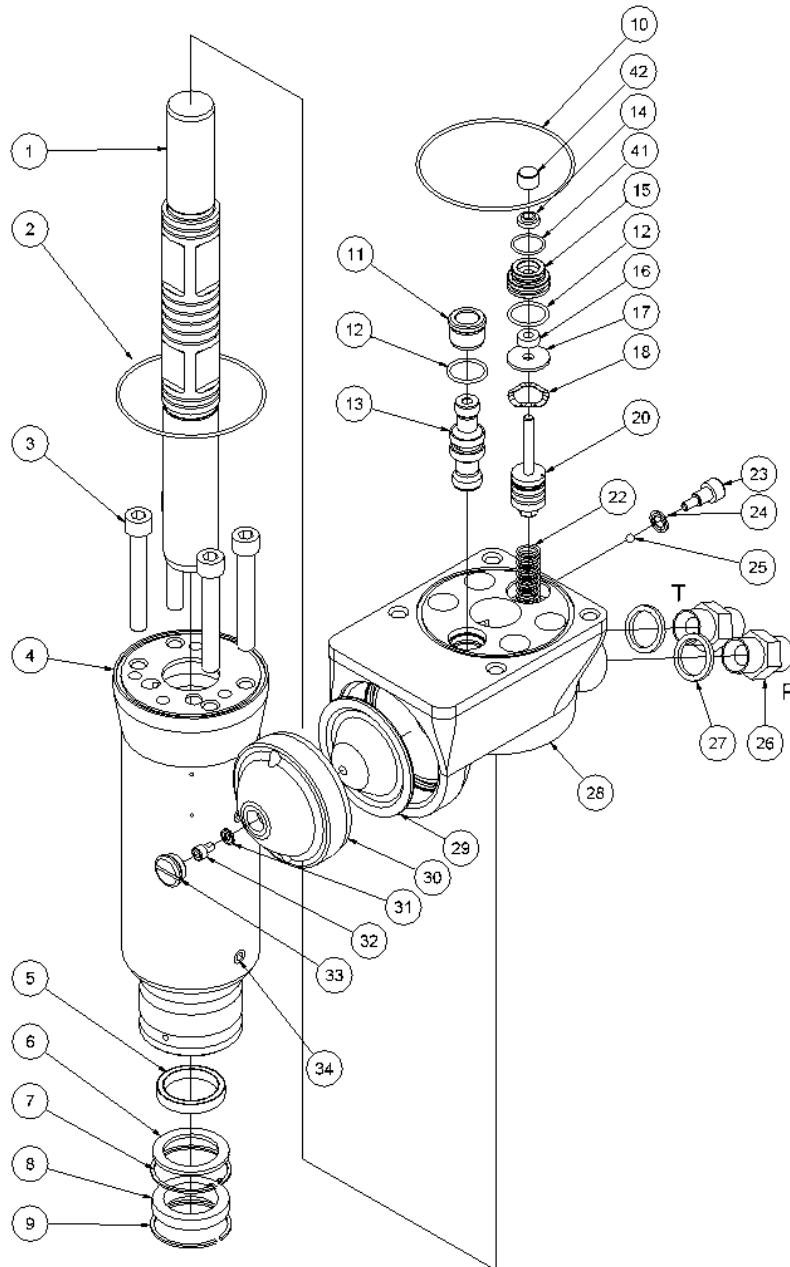

Pos.	Part No.	Description	Pcs.
-	RT801219	1/2" x 12" (1") Single Hose Whip Male SAE - F JIC	1
-	RT801198	Hydraulic Female Quick Disconnect Coupling SAE	1
-	RT801199	Hydraulic Male Quick Disconnect Coupling SAE	1
1	RT8212123	Striking piston	1
2	RT7511247	O-ring 82x2	1
3	RT7611244	Screw M10x70 <i>Tighten crosswise 20-40-80 Nm</i>	4
4	RT9012130	Cylinder	1
5	RT7511232	Seal $\phi 32/\phi 40 \times 6$	1
6	RT8211223	Supporting washer $\phi 32.7 \times 45 \times 2.5$	1
7	RT7611229	Retaining ring	1
8	RT7511234	Rod wiper	1
9	RT7611230	Spring ring	1
10	RT7511246	O-ring 88x2	1
11	RT8211228	Sleeve	1
12	RT7511248	O-ring 20x2	2
13	RT8211200	Spool HH23/HH25 30 l.p.m.	1
14	RT7521013	Seal	1
15	RT8211226	Seal housing	1
16	RT7521014	Seal	1
17	RT8211251	Washer	1
18	RT7611252	Crinkled spring washer 23.8x17.3x0.3	1
20	RT9011750	Trigger piston complete	1
22	RT8611249	Compression spring 1.25x12.5x62.5	1
23	RT8611255	Screw M8 f/lock nut	1
24	RT7511254	Seal ring M8	1
25	RT7611253	Ball $\phi 5$ mm	1
26	RT7421343	Fitting	2
27	RT7521072	Seal ring 1/2"	2
28	RT8212121	Valve housing	1
29	RT7711091	Diaphragm	1
30	RT8211216	Accumulator cover	1
31	RT7511268	Seal ring M5	1
32	RT8611269	Screw M5 f/accumulator <i>Loctite 243</i>	1
33	RT8211256	Plug	1
34	RT7621037	Pipe plug 1/8" <i>Loctite 542</i>	4
41	RT7511300	O-ring 17x1.5	1
42	RT8211227	Distance piece	1
-	RT9011379	Seal kit	1

HPD Post Driver spare parts list

From Serial No. 13110

Fig. 4

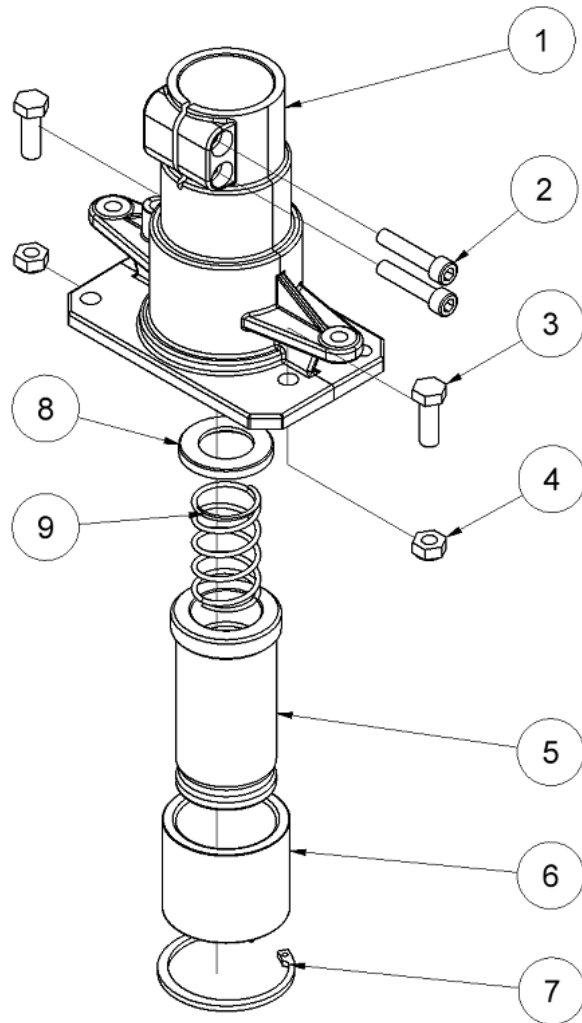

Pos.	Part No.	Description	Pcs.
1	RT8212831	Nose part	1
2	RT7611238	Screw M10x50 <i>Loctite 243 - 40 Nm</i>	2
3	RT7621330	Screw M12x35	2
4	RT7631990	Lock nut M12	2
5	RT8212568	Anvil	1
6	RT8212569	Bushing	1
7	RT7612571	Retaining ring 80x4	1
8*	RT8213408	Spring guide	1
9*	RT7613407	Spring	1

*Installed on HPD from SN: 17414

