



Multi-Pro™ and Multi-Pro XA*

**extended anvil*

GAS/PETROL POST DRIVER OWNERS MANUAL

Serial Numbers: 5005459 or XA04599 and higher



MODEL: 301002 / 301003 / 301007 / 301012 / 301014



TAKE SAFETY SERIOUSLY

This book contains important safety information.
Please read it carefully.

Your safety, and the safety of others, is very important. The proper and safe use of your Rhino® post driver is an important responsibility and should be taken seriously.

Keep this owner's manual available, so you can refer to it at any time. This owner's manual is considered a permanent part of the post driver and should remain with the post driver if resold.

The information and specifications included in this publication were in effect at the time of approval for printing. Rhino Tool Company, Inc. reserves the right, however, to discontinue or change specifications or design at any time without notice and without incurring any obligation whatever. No part of this publication may be reproduced without written permission from:

Rhino Tool Company

To help you make informed decisions about safety, you will find important safety information in a variety of forms, including:

- Safety Labels on the post driver
- Safety Messages Preceded by a safety alert symbol and one of three signal words, DANGER, WARNING, or CAUTION. These signal words mean:



Immediate hazards that will result in severe personal injury or death.



Hazards or unsafe practices that could result in personal injury.



Hazards or unsafe practices that could result in injury, product or property damage.

- Safety Headings such as IMPORTANT SAFETY INFORMATION.
- Safety Section such as POST DRIVER SAFETY.
- Instructions how to use this post driver correctly and safely.

This owner's manual is considered a permanent part of the post driver and should remain with the post driver if resold, rented or loaned.

Rhino® Multi-Pro™ Parts and Accessories List

Multi-Pro™ Standard Configuration

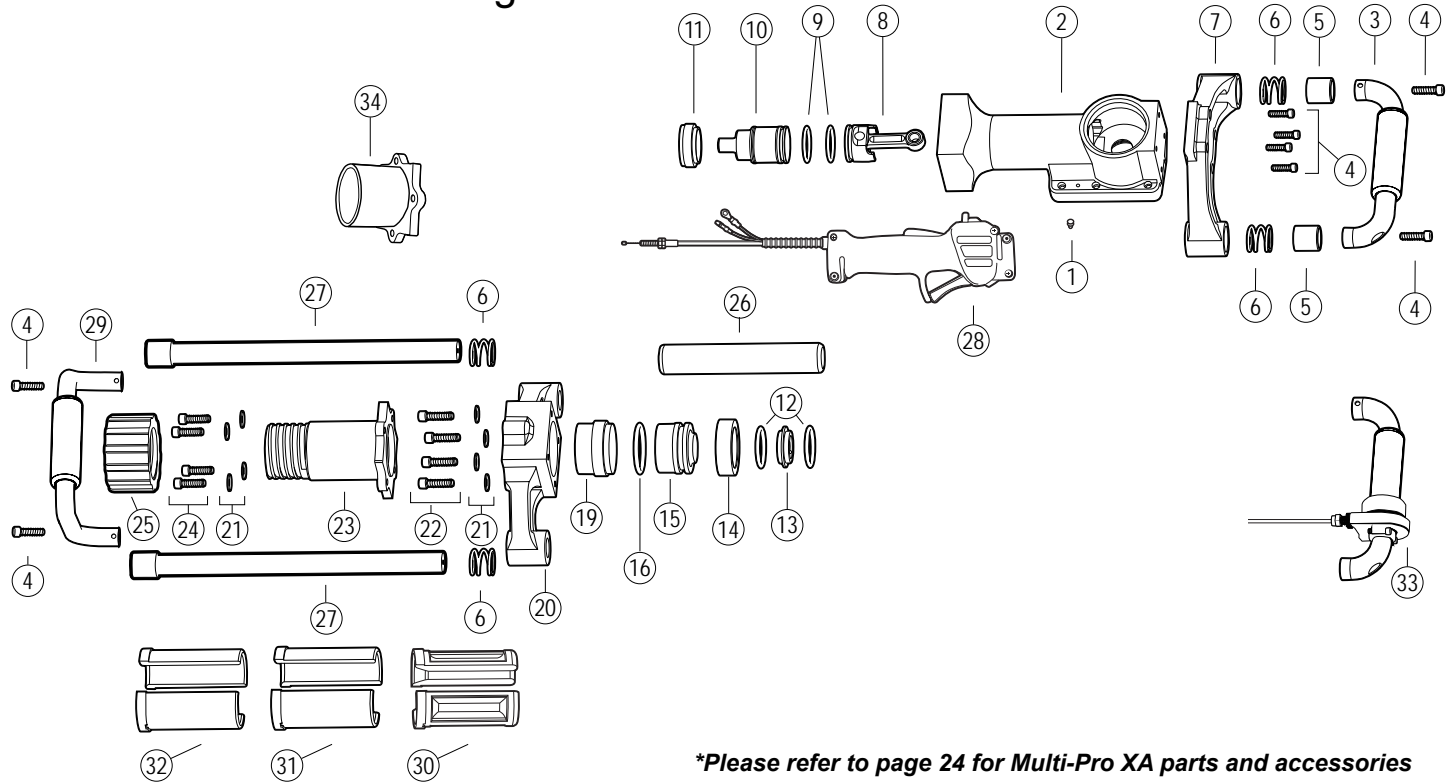

**Please refer to page 24 for Multi-Pro XA parts and accessories*

Rhino® Multi-Pro™ Parts and Accessories List

No.	P/N	Description
1	300712	Ground Bolt
2	301016	Body Assembly with Cylinder and Bearings
3	301222	Top Handle Assembly
4	300715-4	Pro Series Handle Bolt (qty. of 4)
5	301221-2	Handle Collar Set (qty. of 2)
6	610010-4	Handle Springs (qty. of 4)
7	300214	Top Handle Bracket
8	301075	Piston and Connecting Rod Assembly
9	301610-2	Piston and Hammer O-ring Seal Set (qty. of 2)
10	301085	Multi-Pro™ Hammer
11	301097	Multi-Pro™ Anvil O-ring Retainer
12	301614-2	Large Retainer O-ring Seal Set (qty. of 2)
13	301105	Multi-Pro™ Large Retainer
14	301098	Multi-Pro™ Anvil O-ring Cup
15	301165	Anvil (See page 27 for Extended Anvil.)
16	301615	Multi-Pro™ Anvil O-ring Seal
19	301099	Multi-Pro™ Sleeve for Lower Body
20	301032	Multi-Pro™ Lower Body
21	300750-4	Multi-Pro™ Lock Washers (qty. of 4)
22	300701-4	Lower Body Bolt Set (qty. of 4)

No.	P/N	Description
23	301158	Multi-Pro™ Master Chuck
24	300717-4	Multi-Pro™ Chuck Bolt Set (qty. of 4)
25	301920	Chuck-Lok™ Locking Nut (1 per driver)
26	300221	8.5" (216mm) EPDM Foam Grip (1 per driver)
27	301232	Pro-Series Side Handle Assembly
28	300250	Throttle Control Assembly
29	301233	Lower Handle Assembly
30	300900	Chuck-Lok™ System 1" (25.4 mm) Adapter
31	300895	Chuck-Lok™ System 1¾" (44.45 mm) Adapter
32	300902	Chuck-Lok™ System 2" (50.8 mm) Adapter
33	301600	Top Throttle
34	301155	Multi-Pro™ Tent Stake Chuck

Rhino® Multi-Pro™ Parts and Accessories List

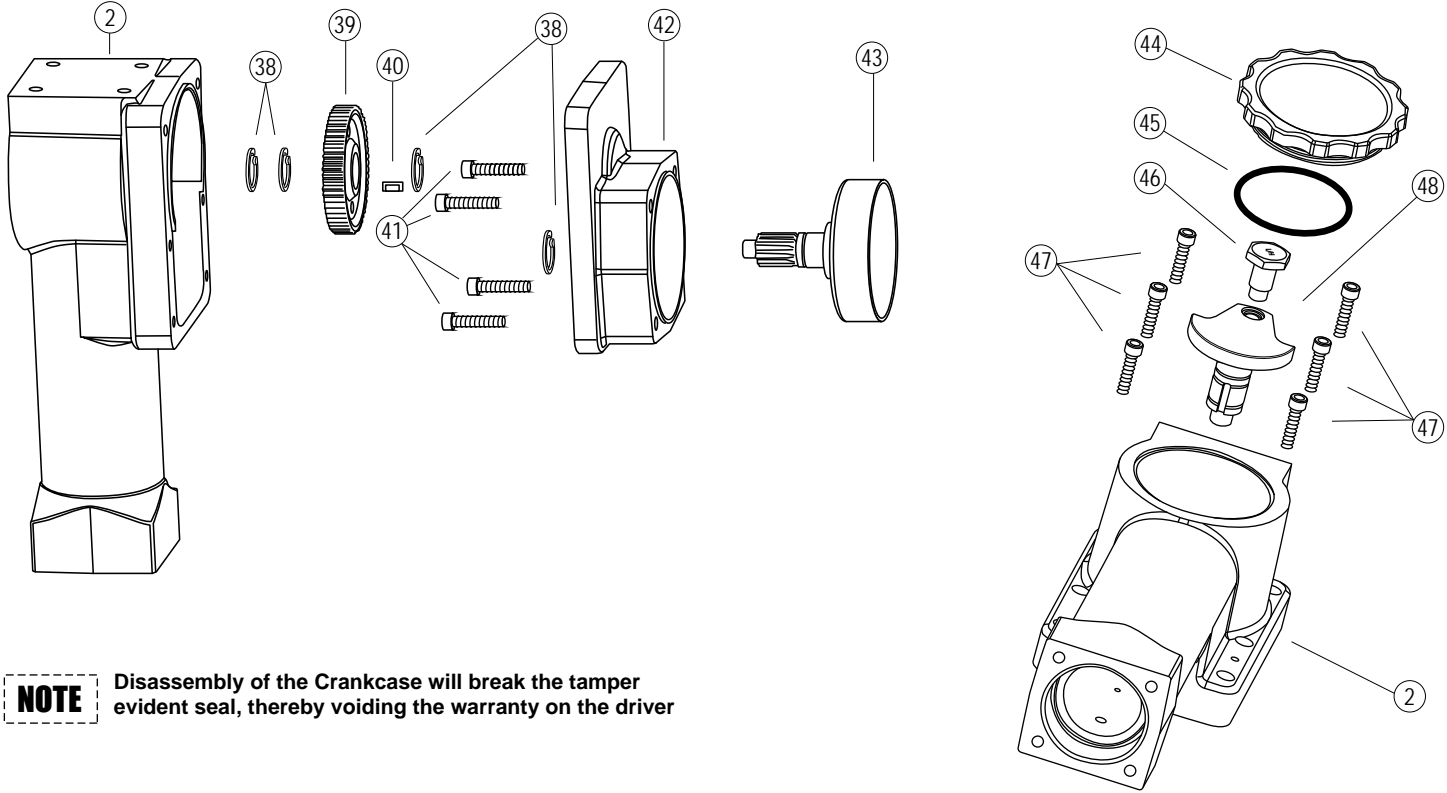

NOTE Disassembly of the Crankcase will break the tamper evident seal, thereby voiding the warranty on the driver

Rhino® Multi-Pro™ Parts and Accessories List



No.	P/N	Description
2	301016	Body Assembly with Cylinder and Bearings
38	300782-4	Retaining Ring Set for Crankshaft & Clutch Drum with Pinion Gear (qty. of 4)
39	300200	Gear
40	300730	Machine Key
41	300700-4	Clutch Housing Bolt Set (qty. of 4)
42	300025	Clutch Housing with Bearings
43	300120	Clutch Drum with Pinion Gear
44	300132	Pro-Series™ Crankcase Cover - Threaded
45	301617	O-ring Seal for Pro-Series™ Crankcase Cover - Threaded
46	300050	Crank Pin (Left Hand Threads)
47	300704-6	Crankcase Bolt Set (qty. of 6)
48	300040	Crankshaft

Rhino® Multi-Pro™ Parts and Accessories List



Multi-Pro™ XA Lower Body Configuration*

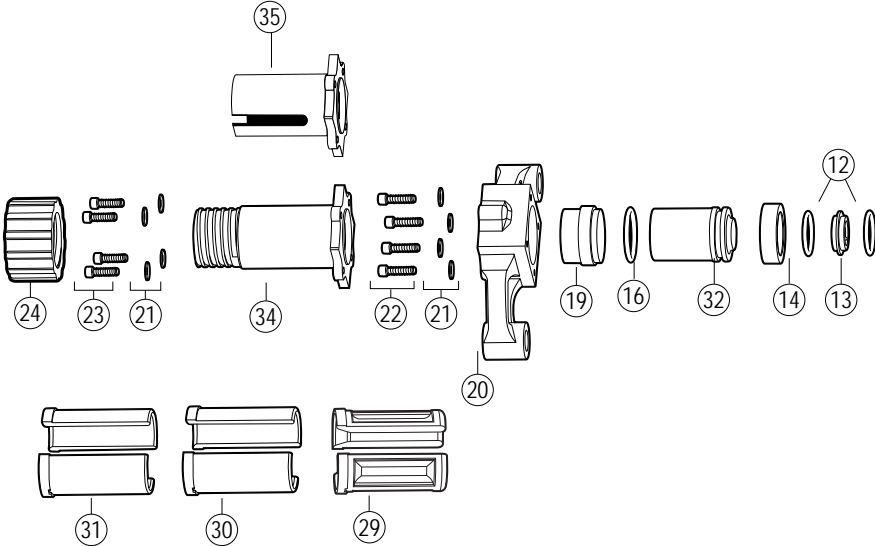

**Please refer to the Multi-Pro Standard Configuration for parts information on the upper portion of the Multi-Pro XA.*

Rhino® Multi-Pro™ Parts and Accessories List

No.	P/N	Description
Multi-Pro XA™ ONLY		
11	301115	Multi-Pro™ Anvil O-ring Retainer
12	301614-2	Large Retainer O-ring Seal Set (qty. of 2)
13	301105	Multi-Pro™ Large Retainer
14	301098	Multi-Pro™ Anvil O-ring Cup
16	301615	Multi-Pro™ Anvil O-ring Seal
19	301099	Multi-Pro™ Sleeve for Lower Body
20	301032	Multi-Pro™ Lower Body
21	300750-4	Multi-Pro™ Lock Washers (qty. of 4)
22	300701-4	Lower Body Bolt Set (qty. of 4)
23	300717-4	Multi-Pro™ Chuck Bolt Set (qty. of 4)
24	301920	Chuck-Lok™ Locking Nut (1 per driver)
29	300900	Chuck-Lok™ System 1" (25.4 mm) Adapter
30	300895	Chuck-Lok™ System 1¾" (44.45 mm) Adapter
31	300902	Chuck-Lok™ System 2" (50.8 mm) Adapter
32	301169	Multi-Pro Extended Anvil
34	301420	Multi-Pro™ Extended Master Chuck
35	301159	Multi-Pro™ Channel Post Chuck (Slotted Chuck)

Rhino® Multi-Pro™ Parts and Accessories List

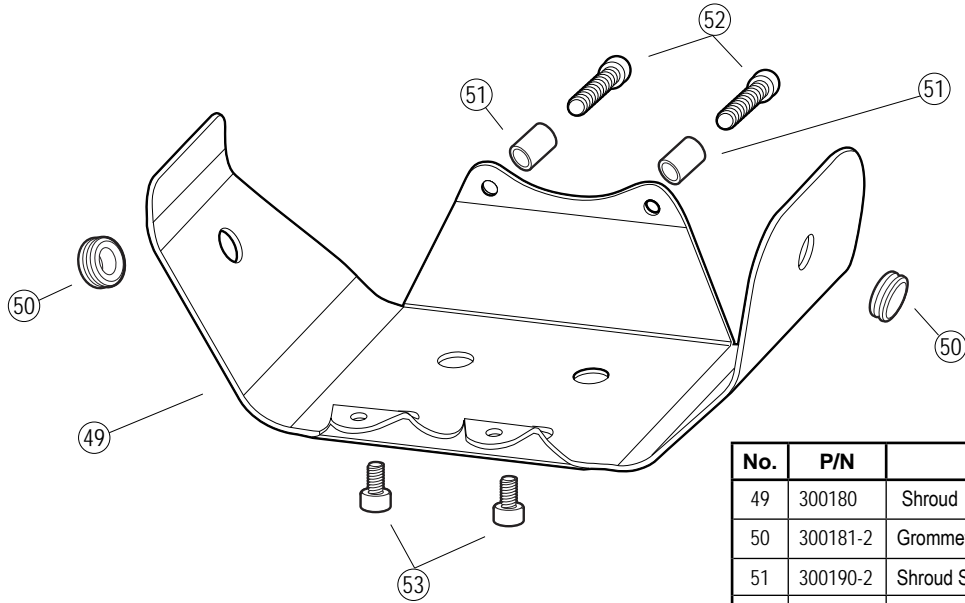

No.	P/N	Description
49	300180	Shroud
50	300181-2	Grommet (qty. of 2)
51	300190-2	Shroud Spacer (qty. of 2)
52	300706-2	Shroud Bolt (qty. of 2)
53	300705-2	Lower Shroud Bolt (qty. of 2)
	300240	Honda GX35 Engine
		Honda Engine Parts are Available from Your Local Honda Dealer
	300805	Safety Label and Tag Set
	301801	Multi-Pro™ Operating, Safety, and Parts Manual

Rhino® Multi-Pro™ Parts and Accessories List

No.	P/N	Description
Accessories		
31	300902	Chuck-Lok™ System 2" (50.8mm) Adapter
30	300895	Chuck-Lok™ System 1½" (44.4mm) Adapter
29	300900	Chuck-Lok™ System 1" (25.4mm) Adapter
24	301920	Chuck-Lok™ Locking Nut (1 required)
	301159	Multi-Pro™ Slotted Chuck
	301169	Multi-Pro™ Extended Anvil
	301175	Multi-Pro™ U-Channel Drive Kit (includes 301159, 301169)
	301155	Multi-Pro™ Tent Stake Chuck
	301400	Large Chuck Adapter (required for all large chucks) Plate*
	301425	Multi-Pro™ Square Tube Chuck
	300932	Drive cap for 1¼" (44.4mm) Square Tube**
	300958	Drive cap for 2" (50.8mm) Square Tube**
	300959	Drive cap for 2½" (57.15mm) Square Tube**
	300960	Drive cap for 2½" (63.5mm) Square Tube**
	301403	Multi-Pro™ 3½" Round Chuck Assembly***
	301405	Multi-Pro™ 4" Round Chuck Assembly***
	301415	Multi-Pro™ 3" Square Chuck Assembly***
	301414	Multi-Pro™ 3" Round Chuck Assembly***
34	301420	Multi-Pro™ Extended Master Chuck

No.	P/N	Description
	301422	Multi-Pro™ XA Square Tube Chuck
	301000	¼" Long Arm Hex Key
	300500	Rhino® Pro Series Lubricant
	300506	Rhino® Pro Series Lubricant - 12-pack
	301509	Multi-Pro™ Service Kit
Bolt Torque Specifications		
4	300715-4	Pro Series Handle Bolts (qty. of 4) - 132 lb/in (14.91 Nm)
21	300701-4	Lower Body Bolts (qty. of 4) - 251 lb/in (28.3 Nm)
23	300717-4	Multi-Pro™ Chuck Bolt Set (qty. of 4) - 251 lb/in (28.3 Nm)
41	300700-4	Clutch Housing Bolt (qty. of 4) - 95.0 in/lbs (10.73 Nm)
46	300050	Crank Pin (Left Hand Threads) - 360.0 in/lbs (40.6 Nm)
47	300704-6	Crankcase Bolt (qty. of 6) - 75.0 in/lbs (8.5 Nm)
52	300706-2	Shroud Bolt (qty. of 2) - 56.4 in/lbs (6.37 Nm)
53	300705-2	Shroud Bolt - Self Tapping (qty. of 2) - 56.4 in/lbs (6.37 Nm)

*Requires 301169 Multi-Pro™ Extended Anvil

**Requires 301425 Square Tube Chuck

***Requires 301400 Large Chuck Adapter Plate

Rhino® Limited Lifetime Impact Warranty Gasoline Powered Post Drivers

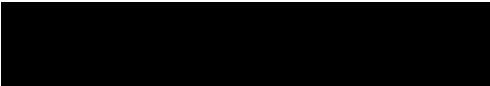

Warranty: Rhino Tool Company, Inc. (“Rhino”) warrants to the original purchaser, purchasing the Equipment in new condition, in original packaging from an authorized dealer that its Gasoline Powered Post Driver will be free from defects in workmanship and materials (the “Limited Warranty”). The Limited Warranty shall survive for the lifetime of the product with respect to the Hammer and Anvil components and for twelve (12) months



with regard to all other components, excluding the Honda GX35 engine for which Rhino provides no warranty and for which the warranty provided by American Honda Motor Co., Inc. shall be the sole warranty applicable thereto. This Limited Warranty is non-transferable.

For Warranty Claims contact your dealer or distributor. Proof of purchase date and serial number is required. In the event of a warranty repair, the post driver should be returned to a Registered and Warranty Authorized Rhino Servicing Dealer. Rhino’s obligation under this Limited Warranty is expressly limited to the repair or replacement, at Rhino’s election, of such defective Gasoline Powered Post Driver, which is proved to be defective upon inspection by a Rhino-certified/authorized technician.

This Limited Warranty does not extend to a Gasoline Powered Post Driver which has been subject to misuse, neglect, or accident, nor does it extend to any Gasoline Powered Post Driver which has been repaired, altered, or serviced by unauthorized persons. This Limited Warranty does not cover any damage or adjustments required to any Gasoline Powered Post Driver if such

damage or adjustment is caused by the use of supplies, parts, or attachments not sold or approved by Rhino

EXCEPT AS OTHERWISE PROVIDED HEREIN, RHINO DISCLAIMS ALL OTHER WARRANTIES, EXPRESS OR IMPLIED, INCLUDING, BUT NOT LIMITED TO THE IMPLIED WARRANTIES OF MERCHANTABILITY AND FITNESS FOR A PARTICULAR PURPOSE. UNDER NO CIRCUMSTANCES SHALL RHINO BE LIABLE FOR ANY LOSS OF BUSINESS, REVENUES, OR PROFIT OR OTHER INDIRECT, INCIDENTAL, SPECIAL OR CONSEQUENTIAL DAMAGES OR LOSS ARISING OUT OF ANY DEFECTS IN OR PERFORMANCE OF THE GASOLINE POWERED POST DRIVER, HOWSOEVER CAUSED.

Registration/Warranty Claims: The purchase of a Rhino Tool, as outlined in the warranty terms, automatically serves as the product registration and the start of the customer’s 1 year warranty. Visit <https://rhinotool.com/service/warranties/gas-petrol-post-drivers/> or call your Rhino Dealer or Rhino customer service toll-free at 1-866-707-1808 for assistance.

End of Lifecycle: When your Rhino Gas Powered Driver (Ranch Pro, Fence Pro, Multi-Pro or Multi-Pro XA) is coming to the end of its lifecycle, destruction of the unit needs to be conducted according to international and local environmental regulations. The gas powered driver contains:

- Fuel
- Oil
- Grease
- Electric components
- Plastic, steel and aluminum components.

Symptom	Explanation/Procedure
Post lodged in the driver with adapter installed	Turn off the engine. Remove the Chuck-Lok™ System's locking nut from the master chuck and slide it down the post. Using the handles, lift post driver upward, allowing the adapter to slide out. If the pressure from the flared post does not allow you to lift driver off the post, locate the pry slots on the adapter base and use a slotted screwdriver to pry them downward. Be careful not to damage the master chuck threads. Once loosened, lift using the post driver handles. As the two-piece adapter frees from the chuck tube they separate from the post. Slide the locking nut off the post, reinsert the adapter, apply the locking nut and resume post driving.
Post lodged in master chuck:	Turn off the engine. Remove the four chuck bolts and separate the master chuck from lower body. Slide the master chuck down the post to expose the flared top of the post. With the proper cutting tool for the type of post, cut through the post below the flared portion. Once the flared portion is removed, slide the master chuck off the post and reassemble the chuck to the driver. Please follow bolt tightening procedure and use threadlocker solution. Recommendation: Do not use "thin-wall" or light gauge round post, which may deform or flare the post at full throttle.
Drives post slow or sluggish engine performance:	Typically this is resulting from improper driver storage or over-filling the oil causing the oil to seep into the combustion chamber. Turn off the engine. Position the driver vertically; remove the dipstick to check oil level. (See page 6) If you need to remove some oil, dispose of it properly. If oil is at proper level, follow the procedure listed in "Pull-start is frozen or hard to pull." It is also good practice to wipe clean the engine after use.
Pull-start is frozen or hard to pull:	This typically results from oil seeping into the combustion chamber from improper driver storage or overfilling the oil reservoir of the engine. Remove spark plug and pull hand grip several times until it pulls freely. Replace the spark plug. Check the oil level in oil reservoir to ensure proper level (page 6). Follow starting procedure. It is not unusual, for blue smoke to be emitted from the engine, let the engine run until smoke clears.
Proper Storage:	Do not lay horizontally on the driver side or resting on the engine. If the unit cannot be stored securely in the upright position, place the chuck on a flat surface, leaning toward the engine side until it is supported by the shroud and chuck. Position the driver on an angle with the top handle at the topmost point.
Other problems or technical questions	Other problems or technical questions: Document your serial number and contact Rhino Tool Company. Phone: 309.853.5555 or Toll Free 866-707-1808, Fax:309.856.5905, Email: service@rhinotool.com . In Europe contact Eurogate Int. F: (0031) (0) 523 638286, M: (0031) (0) 610 502607.



A TRADITION OF QUALITY AND SERVICE SINCE 1975

WWW.RHINOTOOL.COM

Form 301801-100821

Rhino Tool Company, Inc. | P.O. Box 111 | Kewanee, IL 61443