

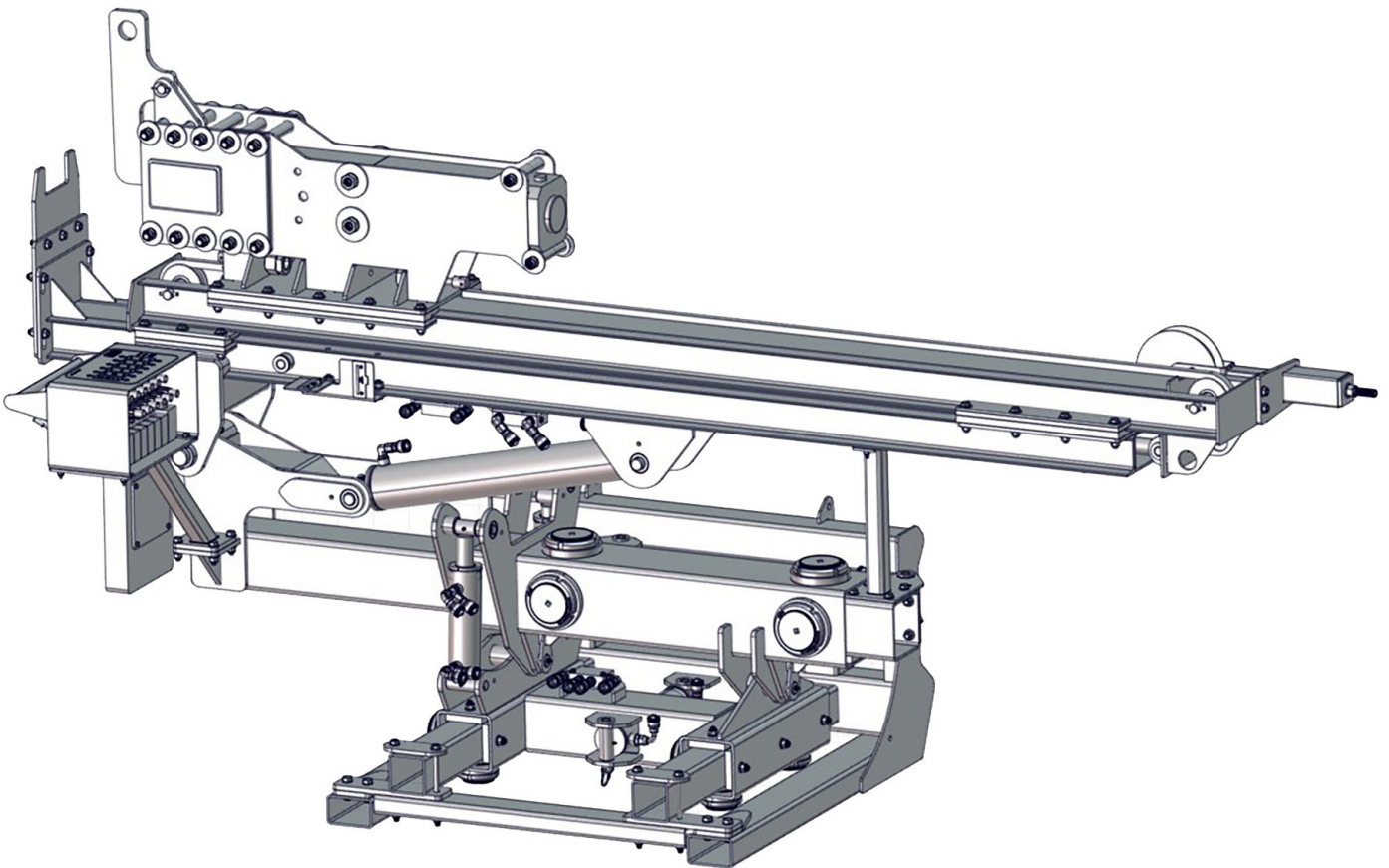

# Rhino Solar Pro - Omni Adjustable Skidsteer Mounted Pile Driver



## Operation And Parts Manual

# Table Of Contents

---

|  |           |
|--|-----------|
| <b>1. Introduction</b> .....                               | <b>4</b>  |
| <b>2. Safety</b> .....                                     | <b>5</b>  |
| <b>2.1 Safety Alert Symbols And Signal Words</b> .....     | <b>5</b>  |
| <b>2.2 Operational Hazards</b> .....                       | <b>5</b>  |
| 2.2.1 Properly Trained Operator .....                      | 5         |
| 2.2.2 Mount And Dismount Properly .....                    | 6         |
| 2.2.3 Electrical Line And Underground Utility Hazard ..... | 6         |
| 2.2.4 Personal Protective Equipment Required.....          | 6         |
| 2.2.5 Pressurized Fluids.....                              | 7         |
| 2.2.6 Prepare For Emergencies .....                        | 7         |
| 2.2.7 Replace Safety Signs .....                           | 7         |
| 2.2.8 Do Not Allow Riders .....                            | 7         |
| 2.2.9 Hazards From Modifying Equipment.....                | 7         |
| 2.2.10 Detaching From Skid Steer.....                      | 7         |
| <b>2.3 Maintenance Hazards</b> .....                       | <b>7</b>  |
| 2.3.1 Lockout/Tagout.....                                  | 8         |
| <b>2.4 Safety Decals</b> .....                             | <b>9</b>  |
| <b>3. Specifications</b> .....                             | <b>12</b> |
| 3.1 Pile Driver .....                                      | 12        |
| 3.2 Skidsteer Requirements .....                           | 12        |
| <b>4. Components</b> .....                                 | <b>13</b> |
| <b>5. Transporting</b> .....                               | <b>14</b> |
| <b>6. Operation</b> .....                                  | <b>15</b> |
| 6.1 Daily Inspections .....                                | 15        |
| 6.2 Pile Driver Operation .....                            | 15        |
| 6.2.1 Drive Post.....                                      | 16        |
| 6.2.2 Pull Post .....                                      | 18        |
| <b>7. Maintenance</b> .....                                | <b>21</b> |
| 7.1 Hammer Lubrication .....                               | 21        |
| 7.2 Grease Fittings.....                                   | 21        |
| 7.3 Lubricate Mast Chain .....                             | 22        |
| 7.4 Telescoping Tubes .....                                | 22        |
| 7.5 Adjust Hammer Down Pressure .....                      | 23        |

# ***Table Of Contents***

---

|  |           |
|--|-----------|
| <b>8. Troubleshooting .....</b>                | <b>24</b> |
| <b>9. Warranty .....</b>                       | <b>25</b> |
| <b>10. Parts.....</b>                          | <b>26</b> |
| <b>10.1 Mast.....</b>                          | <b>26</b> |
| <b>10.2 Center Section .....</b>               | <b>30</b> |
| <b>10.3 Lower Frame .....</b>                  | <b>34</b> |
| <b>10.4 Hydraulic Hoses And Fittings .....</b> | <b>36</b> |

# Introduction

---

## 1. Introduction

Read and understand this manual before using the pile driver and follow all of the safety instructions. Keep this manual with the pile driver at all times.

Carefully examine the pile driver upon receipt. Report any damage immediately to the freight carrier and register any claim.

Information provided in this manual was current as of the issue date. Rhino Tool Company reserves the right to make design changes without further notice or liability.

This manual explains the operation and routine maintenance of the Rhino Solar Pro Pile Driver.

Information furnished in this manual does not include all of the details of design, production, or variations of the equipment. It does not cover all the possible contingencies, which may arise during operation, setup, or maintenance. Should special issues arise, or further information be desired, please contact your Rhino Tool dealer.

The text contained in this manual is for current production models. Some instructions and maintenance procedures may not apply to your specific unit.

Equipment modifications from original design and specifications are strictly prohibited. Modifications or overloading may compromise safe operation of the pile driver, subjecting users to serious injury or death and may void any remaining warranty.

Rhino Tool Company reserves the right to change, improve, modify or expand features of this equipment at any time. Specifications, models, or equipment are subject to change without notice, and without incurring any obligations to change, improve or expand features of previously delivered equipment. Because of the variations in optional equipment and continued design improvement, certain information contained within this manual may not apply.

This operators manual does not replace, nor does its use release the owner/operator from observing all safety codes or operating limitations as well as any applicable federal, state, provincial or local regulations.

The pile driver is designed to be used by experienced operators, trained in the safe operation of a skidsteer and trained in the hazards related to using the pile driver and the safe use of the pile driver for the intended purpose.

Serious injury or death of the operator or bystanders may be caused if the pile driver is misused. Misuse may also cause damage to the skidsteer carrying the pile driver.

## 2. Safety

### 2.1 SAFETY ALERT SYMBOLS AND SIGNAL WORDS

Before setting up, operating or servicing the pile driver, you must read, understand and follow the instructions and safety warnings in this manual. Your machine may not be equipped with some of the optional equipment described in this manual.

If you have any safety concerns or questions that are not covered by this manual, please contact your Rhino Tool dealer.

The safety information in this manual is denoted by the safety alert symbol:  This symbol means ATTENTION! BECOME ALERT! YOUR SAFETY IS INVOLVED!

The level of risk is indicated by the following signal words:

#### DANGER

Indicates a hazardous condition that will result in serious injury or death if not performed appropriately.

#### WARNING

Indicates a hazardous condition that could result in serious injury or death if not performed appropriately.

#### CAUTION

Indicates a hazardous condition that could result in serious injury if not performed appropriately.

#### NOTICE

Indicates a situation that could result in damage to the machine or other property.

### 2.2 OPERATIONAL HAZARDS

The following hazards are possible during the operation and maintenance of the pile driver. All operators, maintenance and service personal, or any one working with or near the pile driver must be familiar with all hazards.

Carefully read all safety messages in this manual and on pile driver safety signs. Keep safety signs in good condition and replace missing or damaged safety signs.

New components and repair parts must include the current safety decal.

Keep pile driver in proper working condition.

Know the regulations and laws that apply to you and your industry. This manual is not to replace any regulations or laws. Additional information may be found at: [www.asae.org](http://www.asae.org) or [www.osha.gov](http://www.osha.gov).

If you do not understand any part of this manual, contact your Rhino Tool dealer.

#### 2.2.1 Properly Trained Operator

Operator must be properly trained and understand operator's manual before using the pile driver. Do not allow untrained or unqualified people to operate the pile driver.

It is your responsibility to operate this equipment safely. You must be familiar with the equipment and all safety practices before use.

#### WARNING

Do not operate this pile driver until you read and understand this manual and the manual provided for the hammer.

#### WARNING

Do not operate, work on or around pile driver while fatigued, while under the influence of alcohol, prescription or nonprescription medication, or if feeling ill.

## WARNING

**Prevent injury.**

**Keep bystanders at least 10 ft (3 m) from the operating area during usage.**

### 2.2.2 Mount And Dismount Properly

When you enter or leave machine:

- Maintain a three-point hand/foot contact with the machine. Three-point contact is defined as using one hand and two feet or two hands and one foot at any single time. Face machine when mounting or dismounting.
- Use handholds or steps if provided.
- Never use control levers as handholds.
- Clean your boots and wipe your hands before mounting or dismounting.
- Never jump on or off of the machine.
- Never attempt to mount or dismount a moving machine.
- Never mount or dismount while carrying objects that prevent three-point contact.

### 2.2.3 Electrical Line And Underground Utility Hazard

## DANGER

**Prevent electrocution and/or explosion.**

**Death or serious injury can result if equipment comes near or contacts electrical lines.**

**Electrocution can occur without direct contact. Maintain a 20 ft (6 m) clearance from any electrical line.**

**Contacting a gas line can result in an explosion.**

Check clearance before raising or moving pile driver.

Have underground utilities located before beginning work. In the US or Canada, call 811 (US) or 888-258-0808 (US and Canada).

Also contact any local utilities that do not participate in the One-Call service. In countries that do not have a One-Call service, contact all local utility companies to have underground utilities located.

**The following shall be adhered to when working around electrical lines:**

- Any electrical line or overhead line shall be considered to be an energized electrical line unless and until the person owning the line or the electric utility authority indicates that the line is not an energized electrical line.
- If any part of the skidsteer or pile driver contacts an energized electrical line, the skid steer operator must not attempt to get off the skidsteer. Warn others to leave the area. Contact utility company to de-energize the line. The skid steer operator shall remain at the controls until utility company informs that it is safe to exit the machine.
- Do not return to job site or allow anyone into area until utility company informs that it is safe to do so.

**If you suspect a gas line has been damaged:**

- Immediately shut off skid steer engine.
- Remove any ignition sources.
- Warn others that a gas line has been damaged and that they should leave the area.
- Leave the area as quickly as possible.
- Immediately call the local emergency phone number and the utility company.
- Do not return to area until given permission by emergency personnel and utility company.

### 2.2.4 Personal Protective Equipment Required

All operators must wear ear and eye protection, safety shoes, hard hat and gloves.

Prolonged exposure to loud noise can cause hearing impairment or loss of hearing.

Workers and bystanders must use ear protection while pile driver is in operation.

## 2.2.5 Pressurized Fluids

### **⚠ WARNING**

Hydraulic oil injected into your skin can cause serious injury or death.

Keep your hands and body away from any pressurized leak. Tighten connections before applying pressure.

Lower mast to horizontal position before checking for leaks.

Never use your hand to check for leaks; use a piece of wood or cardboard. If fluid of any kind is injected into the skin, seek immediate medical attention.

## 2.2.6 Prepare For Emergencies

Be prepared in case of emergencies.

Keep a fire extinguisher and first aid kit close to the machine.

Keep emergency phone numbers in your phone. Know your address so emergency services can locate you if an emergency arises.

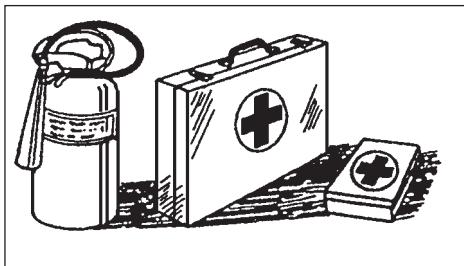

## 2.2.7 Replace Safety Signs

Replace missing or damaged safety signs. Safety signs are identified in this manual. Replacement safety signs are available from your Rhino Tool dealer.

## 2.2.8 Do Not Allow Riders

Never lift or carry anyone on the pile driver. Never use the pile driver as a work platform. Never allow riders on the pile driver.

## 2.2.9 Hazards From Modifying Equipment

Do not make any alterations to the pile driver. Altering the pile driver may cause unsafe conditions and may void the manufacturer's warranty. Always use Rhino Tool Company replacement parts.

## 2.2.10 Detaching From Skid Steer

### **⚠ WARNING**

Roll over hazard.

Pile driver mast must be in the horizontal storage position before disconnecting from skid steer.

Mast must be fully lowered to the horizontal storage position before detaching from skid steer.

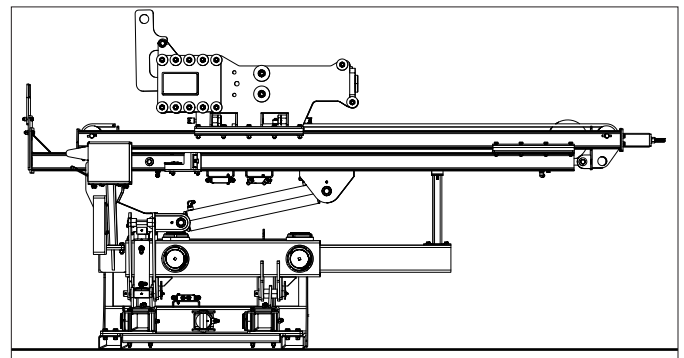

*Storage Position*

## 2.3 MAINTENANCE HAZARDS

The following maintenance and service hazards are in addition to those found while operating the pile driver. All operators, maintenance and service personnel, or any one working with or near the pile driver must be familiar all hazards. If you do not understand any part of this manual, contact your Rhino Tool Dealer.

After performing inspections, service or maintenance, all guards must be reinstalled and verify all safety devices are functional.

Wear personal protective equipment appropriate for the job.

Always use Rhino Tool Company replacement parts. Not using Rhino Tool parts may cause harm to personnel and may void the warranty.

**⚠ WARNING**

Crush hazard.

A raised pile driver can fall, resulting in death or serious injury.

Never enter the area under a raised pile driver.

**⚠ WARNING**

Moving parts can crush and dismember.

Disconnect and lockout power source before adjusting or servicing.

**⚠ WARNING**

Prevent injury.

Wear personal protective equipment appropriate for the job.

**⚠ WARNING**

Hydraulic oil injected into your skin can cause serious injury or death.

Keep your hands and body away from any pressurized leak. Tighten connections before applying pressure.

Lower mast to horizontal position before checking for leaks.

Never use your hand to check for leaks; use a piece of wood or cardboard. If fluid of any kind is injected into the skin, seek immediate medical attention.

**⚠ WARNING**

Cancer and reproductive harm.

For more information go to [www.P65Warnings.ca.gov](http://www.P65Warnings.ca.gov).

## 2.3.1 Lockout/Tagout

**⚠ WARNING**

Crush and pinch hazard.

Keep all personnel clear of all moving components.

Verify all guards are in place.

Follow lockout/tagout procedure before performing service, inspections or maintenance.

Before performing service or maintenance:

- **If pile driver is connected to skid steer:**
  1. Park on a firm and level surface.
  2. Lower pile driver to ground.
  3. Engage skid steer parking brake, stop engine and remove key.
  4. Place a Do Not Operate tag on control panel.
- **If pile driver is not connected to skid steer:**
  1. Pile driver mast must be in the horizontal storage position.
  2. Pile driver must be sitting on firm and level ground.



## 2.4 SAFETY DECALS

Safety decals are located on the pile driver to identify both operational and maintenance hazards. These safety decals are placed according to the hazard in that area of the machine.

Read and understand each safety decal and the hazard it references. These safety messages are additional information to the safety content already described in this section of the operators manual.

All safety decals must be legible at all times. Keep them clean by using soap and water, avoid using harsh chemicals or pressure washing. If the safety decal is no longer legible, replace it with a new one. Contact your Rhino Tool dealer for new decals. The part number of the decal is located on the decal and on the images of the safety decals that follow.

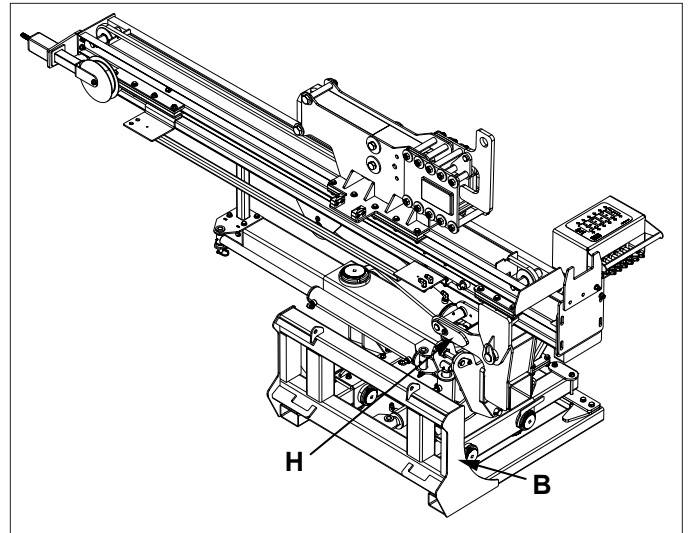
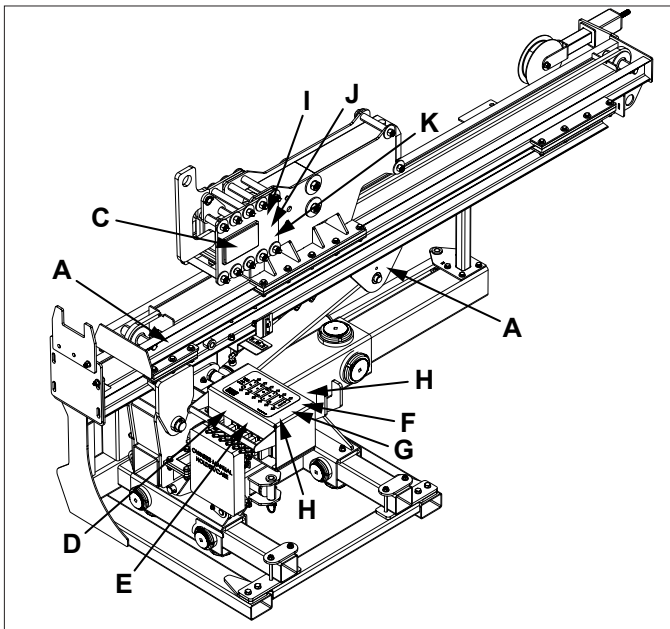

Decal A - 00601

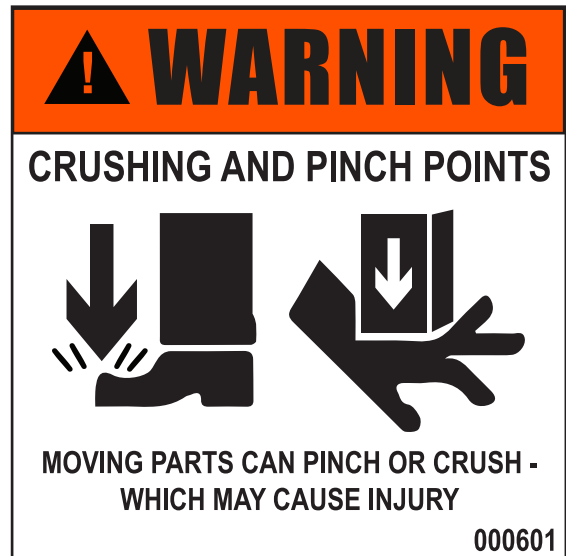

Decal B - 00611



Decal C - 00602

**⚠ WARNING**

**AVOID INJURY OR DEATH**

Read and follow operating instructions.  
**ALWAYS WEAR PPE**

**BE AWARE** of surroundings and use caution when operating this equipment.

**DO NOT** place hands near post when hammer is in use.

**TURN OFF** all equipment, release pressure, and completely lower attachment into a horizontal position before attempting repairs.

**DO NOT** transport the attachment in the raised position.

**DO NOT** stand in front of the post when the attachment is driving the post.

000602

Decal D - 00603

**⚠ WARNING**

**POWER LINES CAN CAUSE SEVERE INJURY OR DEATH**

Maintain a clearance of at least 20 ft (6 m) around any electrical lines or obstructions.

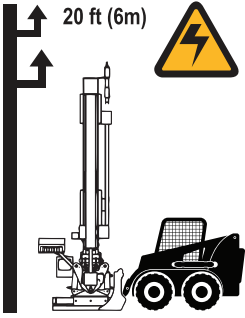

000603

Decal E - 00604

**⚠ WARNING**

**TO AVOID INJURY OR DEATH**

Keep all bystanders at least 10 ft (3m) from the operating area during usage.



10 ft (3m)

000604

Decal F - 00605

**⚠ WARNING**

**AVOID INJURY OR DEATH**

Read and understand the operation manual before operating or servicing this attachment.



000605

Decal G - 00606

**⚠ WARNING**



**PPE REQUIRED**

**ALL OPERATORS MUST WEAR EYE AND EAR PROTECTION SAFETY SHOES, HELMET AND GLOVES BEFORE OPERATING EQUIPMENT**

000606

Decal H - 00607

**⚠ WARNING**



**HIGH PRESSURE  
OIL HAZARD**  
Avoid serious injury  
or death:  
**DO NOT** use body or  
hands to check for leaks

Before checking hydraulic lines  
lower mast down into horizontal  
position, stop engine, and relieve all  
hydraulic pressure before repairing,  
adjusting or disconnecting hoses.

Use a piece of cardboard to check for  
possible leaks. Wear PPE at all times.

Do routine maintenance - do not allow  
hoses to become pinched, tangled,  
worn or loose.

000607

Decal I - 00608

**⚠ CAUTION**

**GREASE HAMMER DAILY**



READ SERVICE  
SCHEDULE IN  
MANUAL FOR ALL  
GREASE POINTS

Access the manual at:  
[rhinotool.com/service](http://rhinotool.com/service)

000608

Decal J - 00609

**⚠ CAUTION**

**PERFORM MAINTENANCE**  
**Before operation:**

- Read Operation Manual
- Check and tighten bolts regularly.
- Visually check hoses for wear.
- Grease major pivot points regularly.

To access the manual online visit  
[www.rhinotool.com/service](http://www.rhinotool.com/service)

000609

Decal K - 00610

**⚠ CAUTION**

**TO PREVENT DAMAGE**

Hammer should be in contact with  
the post when in use. Dry firing the  
unit without a post engaged can  
cause damage to the attachment  
and will void all warranties.

Steady pressure should be  
maintained on the post while in use  
to prevent damage to the hammer.

Adjust the down pressure relief  
valve to driving conditions. Too  
much pressure can lift the unit off  
the ground instead of installing post.  
See operation manual for adjust-  
ment instructions.

000610

# Specifications

## 3. Specifications

### 3.1 PILE DRIVER

|   |  |
|---|--|
| Weight  | 3,000 lbs (1,361 kg)                                 |
| Pile Driving Impact Energy  | 800 ft-lbs (1,085 joules) Per Stroke                 |
| Blows Per Minute  | Approximately 500 to 1,000                           |
| Omni Directional Adjustment For Positioning The Pile And To Accommodate For Uneven Terrain. | Mast Tilts 2 Degrees Left And 90 Degrees Right       |
|   | Mast Tilts 10 Degrees Forward And Backward           |
|   | 10 in. (25.4 cm) Front To Back Adjustment            |
|   | 24 in. (61 cm) Left To Right Adjustment              |
| Maximum Solar Pile Height   | Up To 15 ft (457.2 cm)                               |
| Hydraulic Requirements  | 21 gpm (80 lpm) Oil Flow @ 2610 psi (180 bar)        |
|   | Pressure And Tank Hydraulic Connectors               |
| Operating Hydraulic Pressure  | 1740 - 2320 psi (120 - 160 bar)                      |
| Hydraulic Oil Flow Range  | 10.5 - 22.5 gpm (40 - 85 lpm)                        |
| Hydraulic Fluid Capacity  | App. 5 gal (19 L) - Pre-Filled At Factory            |
| Operating Noise   | 115 DbA  |
| Hydraulic Hammer  | Furukawa Fx55  |
| Pile Driver Dimensions - Folded For Transportation  | Height = 6 ft 3 in. (190.5 cm)                       |
|   | Width = 4 ft 7 in. (139.7 cm)                        |
|   | Length = 11 ft 8 in. (3556 cm)                       |
| Pile Driver Dimensions - Unfolded For Work  | Height = 20 ft (609.6 cm)                            |
|   | Width = 5 ft 4 in. (162.6 cm)                        |
|   | Length = 10 ft 1 in. (307.3 cm)                      |
| Standard Pile Adapter Size  | I Beam "W" Shape Up To 6 x 4 in. (15.2 x 10.2 cm)    |
|   | C-Channel Solar Posts - 4.5 x 6 in. (11.4 x 15.5 cm) |
|   | I Beam "S" Shape Up To 6 in. (15.2 cm)               |

### 3.2 SKIDSTEER REQUIREMENTS

|                                  |                                  |
|----------------------------------|----------------------------------|
| Minimum Operating Weight         | 10,000 lbs (4,536 kg)            |
| Minimum Rated Operating Capacity | 3,000 lbs (1,5360 kg)            |
| Hydraulic Requirements           | 2 Lines - Pressure And Tank      |
| Hydraulic Oil Flow Range         | 10.5 - 22.5 gpm (40 - 80 lpm)    |
| Hydraulic Oil Pressure Range     | 1740 - 2320 psi (2120 - 160 bar) |

## 4. Components

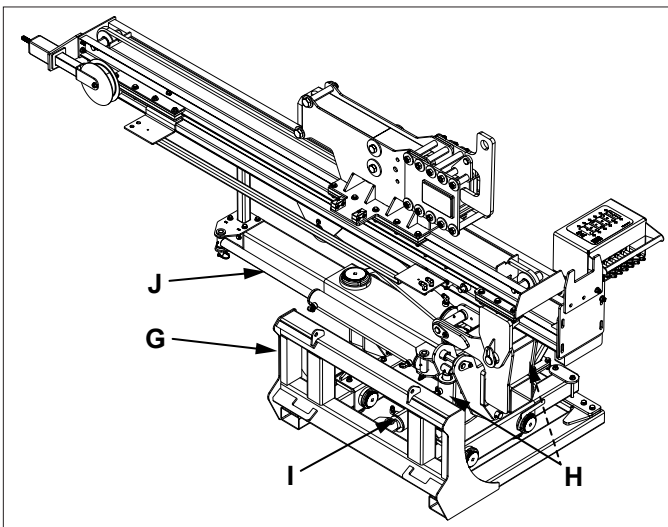
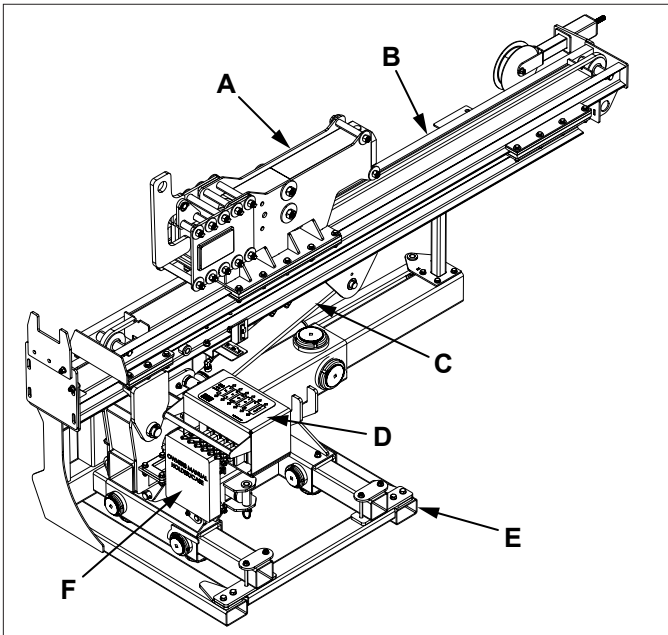

- A. Hammer
- B. Mast
- C. Mast Tilt Up/Down Cylinder
- D. Control Panel
- E. Lower Frame
- F. Operators Manual Holder/Case
- G. Quick Attach Frame
- H. Mast Tilt Fore/Aft Cylinders
- I. Mast Position Fore/Aft Cylinder
- J. Mast Position Left/Right Cylinder

## 5. Transporting

1. Refer to pile driver specifications for weight and dimensions to determine truck or trailer needed to transport pile driver.

**⚠ WARNING**

**Collision hazard.**

**Pile driver must be in the horizontal storage position for transporting.**

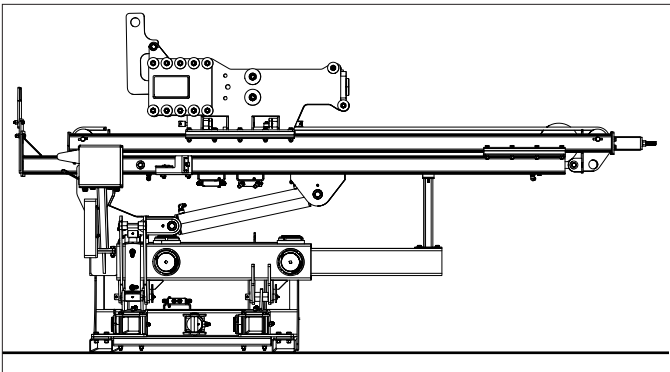

*Storage Position*

2. Position pile driver on truck or trailer.

**⚠ WARNING**

**Collision hazard.**

**Failure to secure pile driver with adequately rated devices may result in pile driver falling off truck or trailer.**

**Verify tie down devices are adequately rated to secure the pile driver.**

3. Connect properly rated tie down devices to pile driver and to truck or trailer.
4. Tighten tie down devices as instructed by the manufacturer to secure pile driver to truck or trailer.

## 6. Operation

### 6.1 DAILY INSPECTIONS

Thoroughly inspect the pile driver before each operation.

#### WARNING

Hydraulic oil injected into your skin can cause serious injury or death.

Keep your hands and body away from any pressurized leak. Tighten connections before applying pressure.

Lower mast to horizontal position before checking for leaks.

Never use your hand to check for leaks; use a piece of wood or cardboard. If fluid of any kind is injected into the skin, seek immediate medical attention.

Verify all safety decals are in place and clearly visible.

Check for loose or missing parts and any damage that may have occurred during operation, moving or shipping.

Review all skid steer pre-start instructions and verify that all recommended steps and procedures have been followed.

### 6.2 PILE DRIVER OPERATION

#### DANGER

Prevent electrocution and/or explosion.

Death or serious injury can result if equipment or post comes near or contacts electrical lines.

Electrocution can occur without direct contact. Maintain a 20 ft (6 m) clearance from any electrical line.

Contacting a gas line can result in an explosion.

#### WARNING

Prevent injury.

Keep bystanders at least 10 ft (3 m) from the operating area during usage.

#### WARNING

Do not operate this pile driver until you read and understand this manual and the manual provided for the hammer.

#### WARNING

Do not operate, work on or around pile driver while fatigued, while under the influence of alcohol, prescription or nonprescription medication, or if feeling ill.

#### CAUTION

Prevent injury.

All operators must wear ear and eye protection, safety shoes, helmet and gloves.

Prolonged exposure to loud noise can cause hearing impairment or loss of hearing.

Bystanders must use ear protection while pile driver is in operation.

#### NOTICE

Prevent hammer damage.

Hammer should be in contact with post before moving hammer lever to on position.

Dry firing hammer without a post engaged may damage hammer.

## 6.2.1 Drive Post

1. Have underground utilities located before beginning work. In the US or Canada, call 811 (US) or 888-258-0808 (US and Canada).

Also contact any local utilities that do not participate in the One-Call service. In countries that do not have a One-Call service, contact all local utility companies to have underground utilities located.

2. Attach skidsteer to pile driver. See skid steer operators manual.
3. Connect hydraulic hoses to skid steer.
4. Check overhead and side clearances before raising mast or moving pile driver. Verify there is clearance above pile driver to safely raise mast.
5. Position pile driver approximately 2 ft (0.6 m) on left side of desired location to drive post.
6. Engage skid steer parking brake.
7. Lower pile driver so lower frame is on the ground.
8. Set skid steer engine to low/medium speed and engage hydraulics to pile driver.
9. Push mast tilt lever (A) down to raise mast. Release lever when mast is in a straight up position.

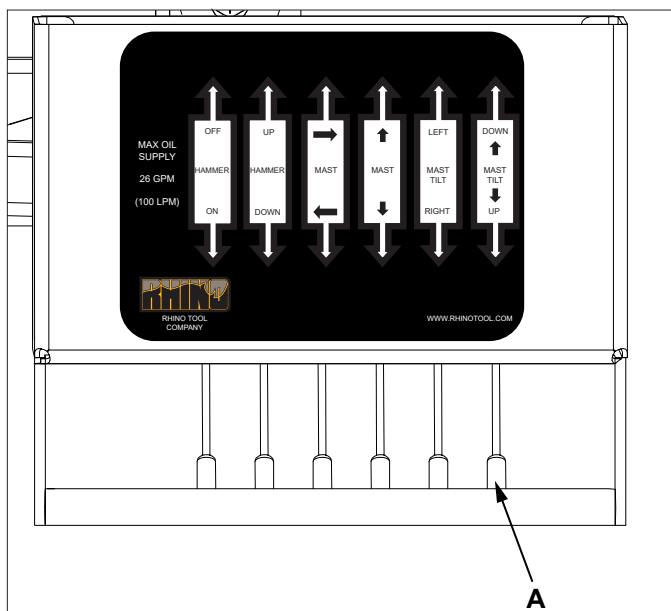

10. Operate levers (B) and (C) to position mast directly over location for post.

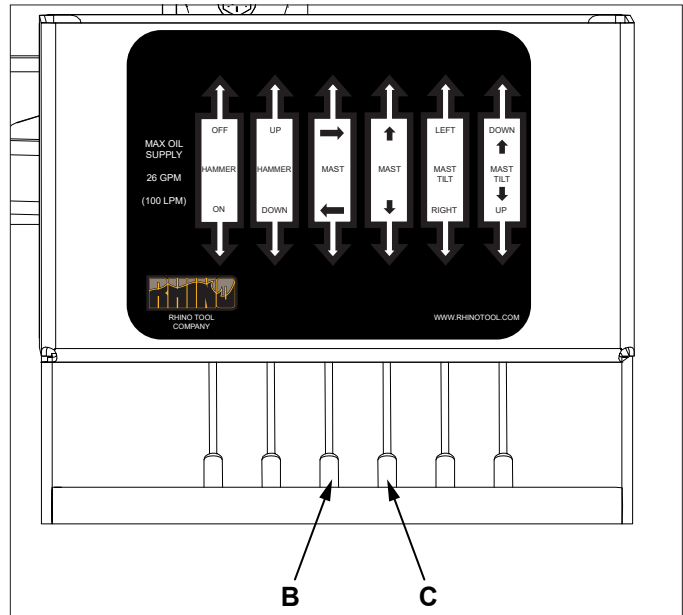

11. Operate levers (A) and (D) to plumb mast. Levels are mounted on mast frame. If on a slope, skid steer may need to be repositioned get mast in a plumb position.

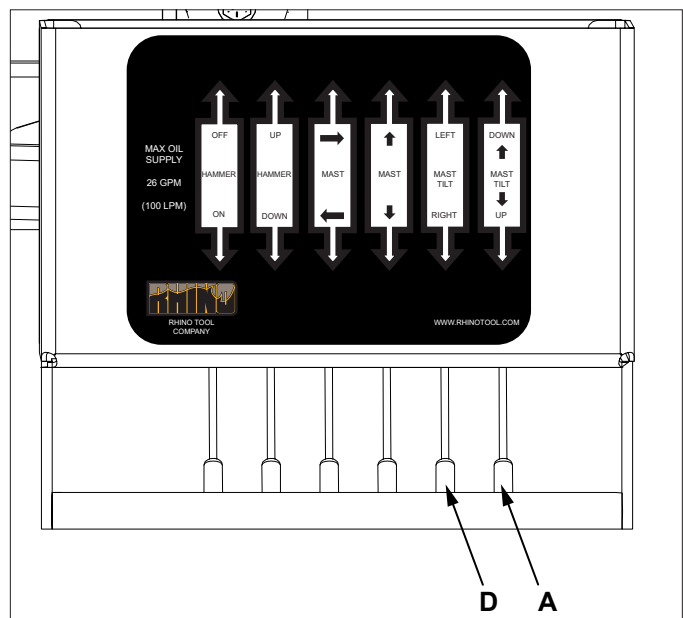



# Operation

12. Operate lever (E) and raise hammer to top of mast.

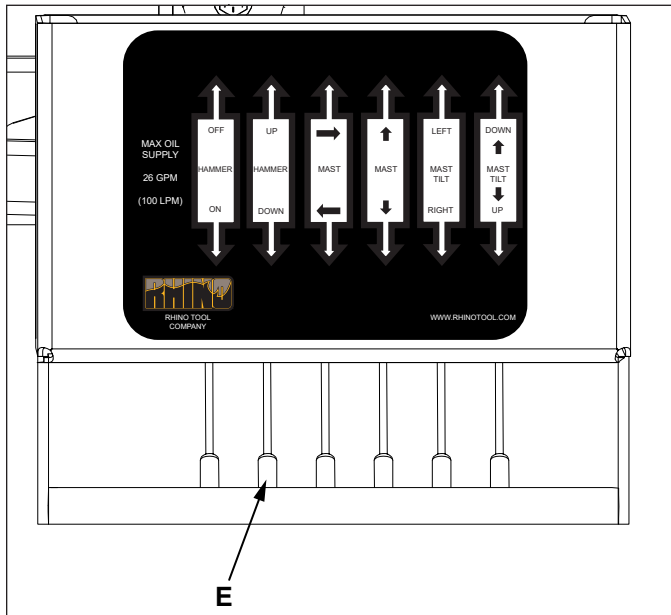

## NOTICE

**Prevent hammer damage.**

**Hammer should be in contact with post before moving hammer lever to on position.**

**Dry firing without a post engaged may damage hammer.**

13. Place end of post on desired location on ground. Post must be inside of bracket on mast as shown. Adjust mast position if needed.



14. Hold post in position under hammer and slowly lower mast using lever (E). Apply a slight downward pressure on post.

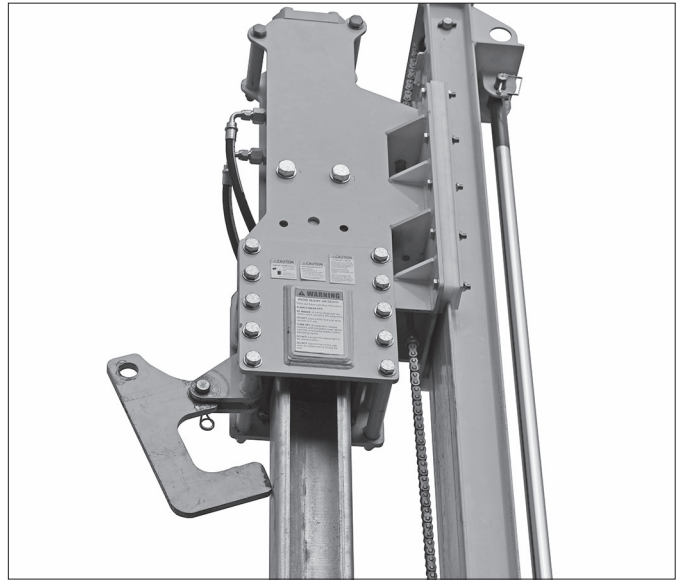

15. While keeping a slight downward pressure on post, place a level on post and adjust mast left/right and fore/aft position if needed to plumb post.
16. Increase skid steer engine speed to high idle.
17. Push mast lever (E) down to apply down pressure on post and move hammer lever (F) down to drive post into ground. Mast frame must not lift off ground when applying down pressure. If additional down pressure is required, see Adjusting Hammer Down Pressure in Maintenance Section.

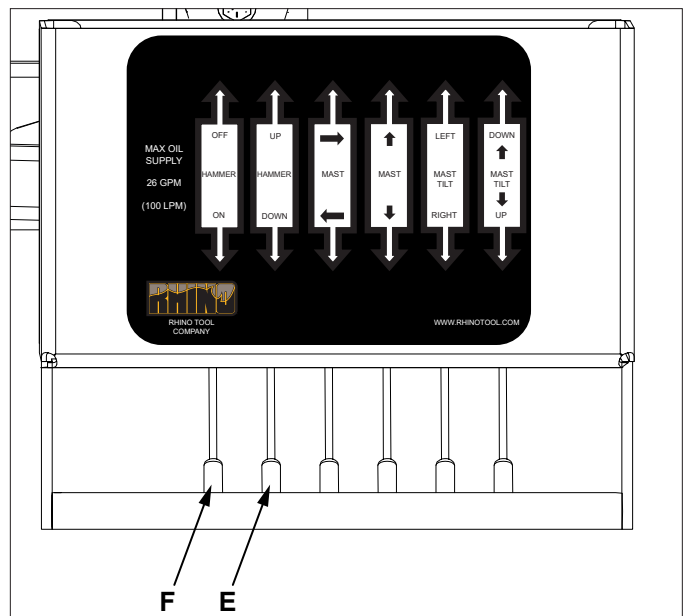

# Operation

18. Release levers (F), then (E) when post is at desired height.
19. If traveling a short distance to next post location on a level surface, mast can remain in the up position. Verify there are no overhead obstructions in the travel path. Travel at a slow speed.

If traveling a short distance to next post location on an uneven surface, mast must be tilted down to storage position using lever (A) before traveling. Travel at a slow speed.

If traveling any distance farther than the next post location, mast must be tilted down to storage position using lever (A) before traveling. Travel at a slow speed.

20. Repeat steps 4-19 for each additional post.

## WARNING

**Roll over hazard.**

**Pile driver mast must be in the horizontal storage position before disconnecting from skid steer.**

21. Tilt mast down to horizontal storage position using lever (A) before detaching from skid steer.

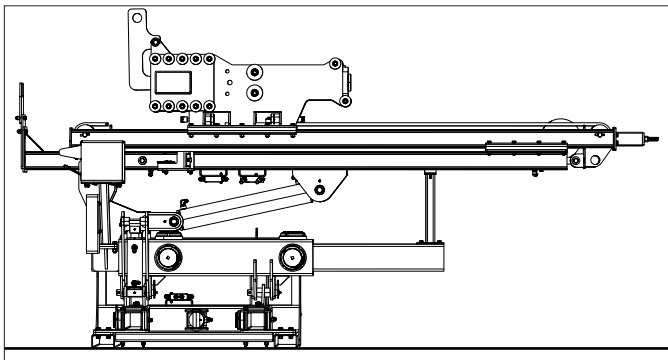

*Storage Position*

## 6.2.2 Pull Post

1. Attach skidsteer to pile driver. See skid steer operators manual.
2. Connect hydraulic hoses to skid steer.
3. Check overhead and side clearances before raising mast or moving pile driver.
4. Position pile driver approximately 2 ft (0.6 m) from post.
5. Lower pile driver so lower frame is on the ground.
6. Engage skid steer parking brake.
7. Set skid steer engine to low/medium speed and engage hydraulics to pile driver.
8. Push mast tilt lever (A) down to raise mast. Release lever when mast is in a straight up position.

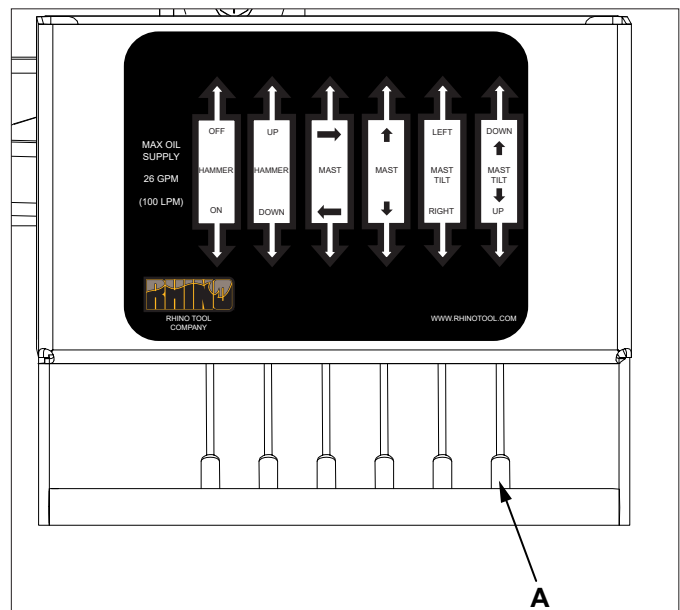

# Operation

9. Operate levers (B) and (C) to position mast close to post.

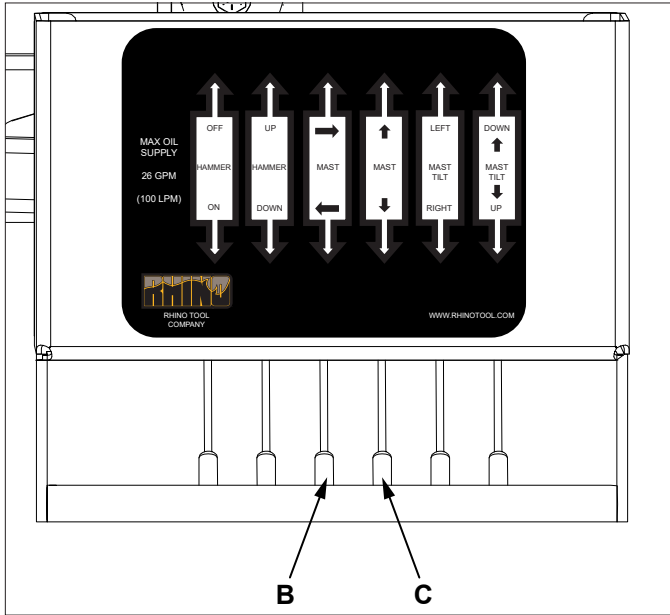

11. Operate lever (E) and position hammer as needed, just slightly above post.

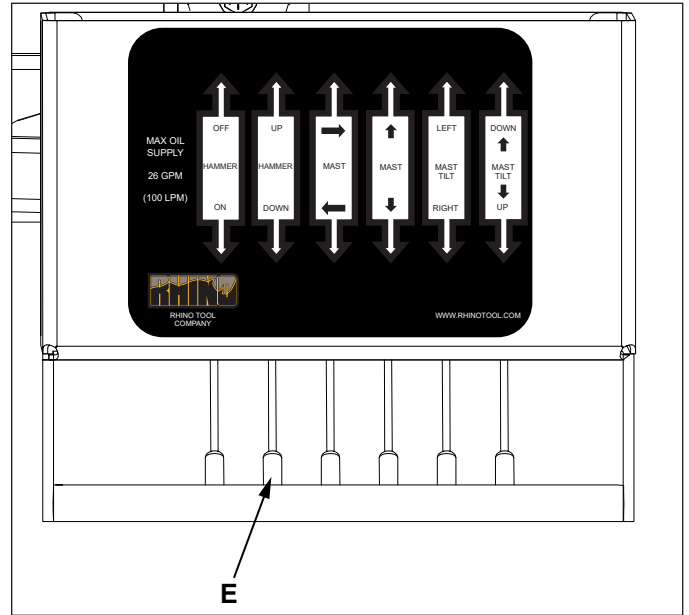

10. Operate levers (A) and (D) to plumb mast. Levels are mounted on mast frame. If on a slope, skid steer may need to be repositioned get mast in a plumb position.

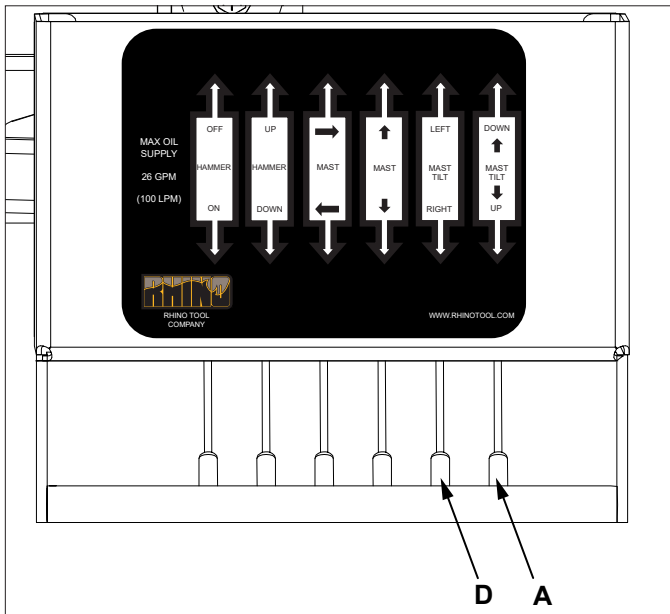

12. Connect post puller to hammer and post as shown.



# Operation

13. Pull mast lever (E) up to apply upward pull on post and move hammer lever (F) down to pull post from ground.

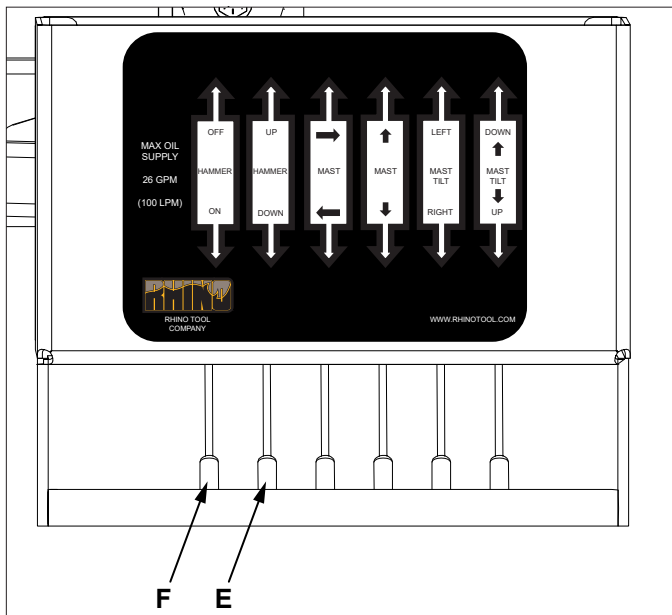

14. Release levers (F), then (E) when post is out of the ground.
15. Disconnect post from hammer.
16. If traveling a short distance to next post location on a level surface, mast can remain in the up position. Verify there are no overhead obstructions in the travel path. Travel at a slow speed.

If traveling a short distance to next post location on an uneven surface, mast must be tilted down to storage position before traveling using lever (A). Travel at a slow speed.

If traveling any distance farther than the next post location, mast must be tilted down to storage position using lever (A) before traveling. Travel at a slow speed.

17. Repeat steps 3-16 for each additional post.

## **⚠ WARNING**

**Roll over hazard.**

**Pile driver mast must be in the horizontal storage position before disconnecting from skid steer.**

18. Tilt mast down to horizontal storage position using lever (A) before detaching from skid steer.

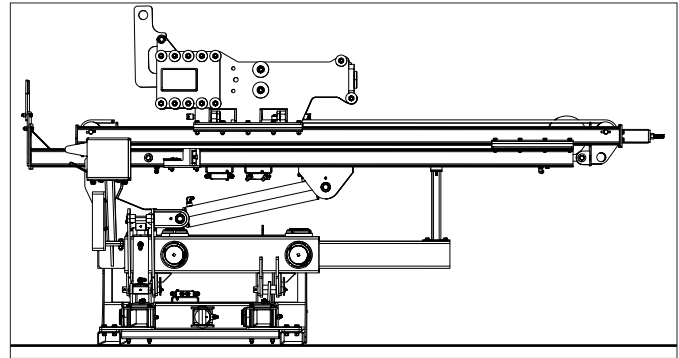

*Storage Position*

## 7. Maintenance

### **⚠ WARNING**

Crush and pinch hazard.

Keep all personnel clear of all moving components.

Verify all guards are in place.

Follow lockout/tagout procedure before performing service, inspections or maintenance.

### **⚠ WARNING**

Crush hazard.

A raised pile driver can fall, resulting in death or serious injury.

Never enter the area under a raised pile driver.

### **⚠ WARNING**

Moving parts can crush and dismember.

Disconnect and lockout power source before adjusting or servicing.

### **⚠ WARNING**

Hydraulic oil injected into your skin can cause serious injury or death.

Keep your hands and body away from any pressurized leak. Tighten connections before applying pressure.

Lower mast to horizontal position before checking for leaks.

Never use your hand to check for leaks; use a piece of wood or cardboard. If fluid of any kind is injected into the skin, seek immediate medical attention.

### **⚠ WARNING**

Prevent injury.

**Wear personal protective equipment appropriate for the job.**

Before performing service or maintenance:

- **If pile driver is connected to skid steer:**
  1. Park on a firm and level surface.
  2. Lower pile driver to ground.
  3. Engage skid steer parking brake, stop engine and remove key.
  4. Place a Do Not Operate tag on control panel.
- **If pile driver is not connected to skid steer:**
  1. Pile driver mast must be in the horizontal storage position.
  2. Pile driver must be sitting on firm and level ground.

### 7.1 HAMMER LUBRICATION

Lubricate hammer per the OEM manufacturers recommendations. See hammer operators manual.

### 7.2 GREASE FITTINGS

All grease fittings are accessible with pile driver mast in the horizontal storage position.

Pump a grade 2 general purpose lithium grease into each fitting monthly. Grease fittings are located on each cylinder end and all pivot points.

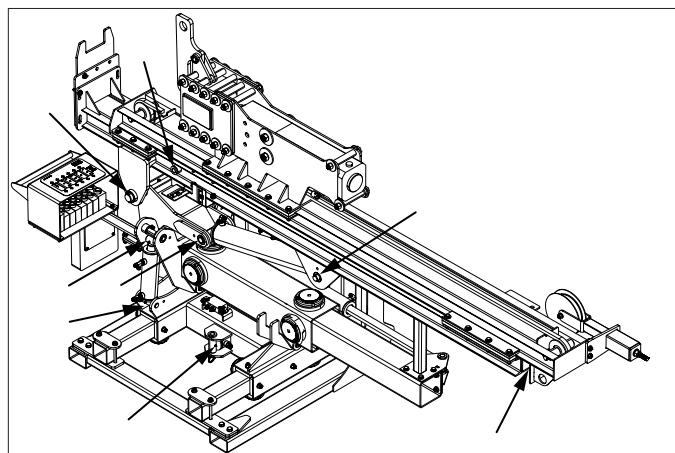

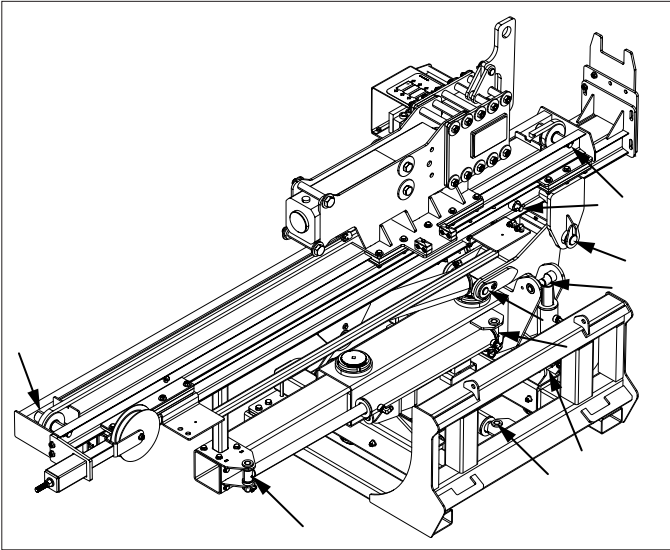

## 7.3 LUBRICATE MAST CHAIN

Lubricate mast chain based on your usage and how the pile driver is stored.

- Stored outside and heavy/daily use - Weekly.
- Stored inside and heavy use - Every 2 weeks.
- Stored inside and light use - Every 3-4 weeks.

Use a lithium spray grease suitable for chains.

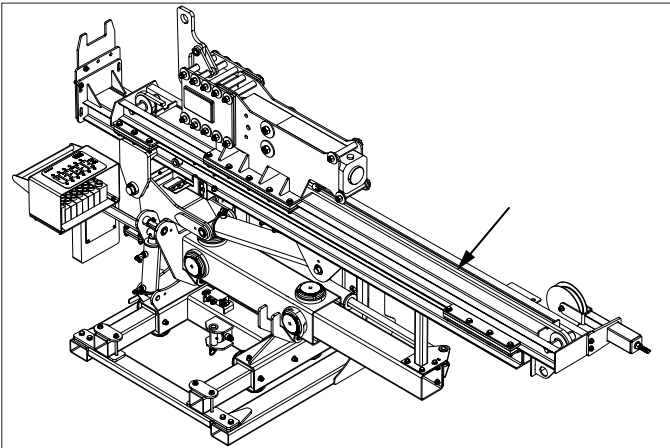

## 7.4 TELESCOPING TUBES

1. Each telescoping tube will have four adjustable guides. The inner tubes (A) should not be loose inside the outer tubes (B).
2. If inner tube is loose, loosen nut (C) with spanner wrench provided with pile driver.
3. Turn screw (D) with 1/2 in. ratchet until snug.
4. Tighten nut (C).

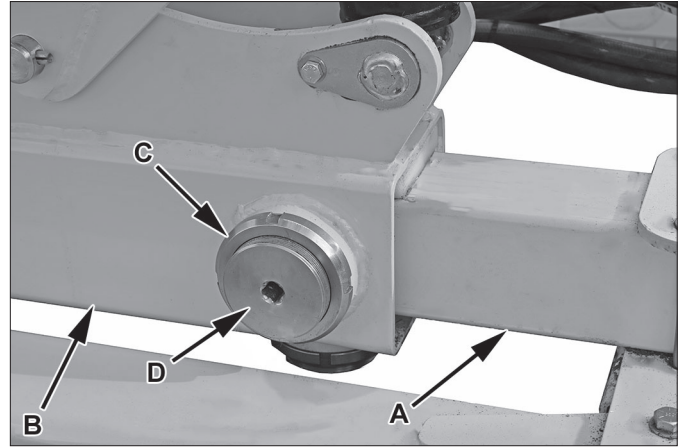

## 7.5 ADJUST HAMMER DOWN PRESSURE

Hammer down pressure is adjustable if more or less hammer down pressure is required when driving post.

Down pressure is set at the factory and should be sufficient for most operations.

Valve is located on mast and marked with red paint.

1. Hold adjusting screw (A) with hex wrench and loosen locknut (B).
2. Turn screw (A) clockwise to increase down pressure, or counter clockwise to decrease down pressure. Turn screw (A) 1/2 turn increments.
3. Hold screw (A) in position and tighten locknut (B).
4. Test operation. Adjust as needed to get desired down pressure.

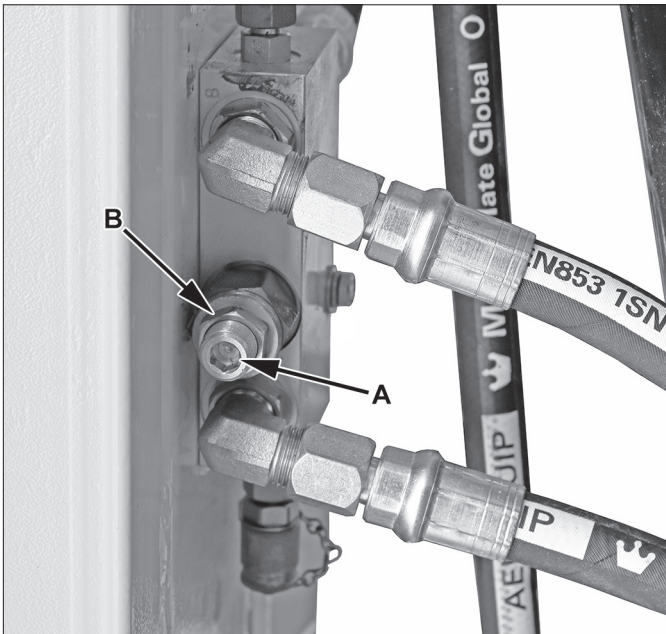

# Troubleshooting

---

## 8. Troubleshooting

| <b>Problem</b>  | <b>Possible Cause</b>                | <b>Solution</b>   |
|---|--------------------------------------|---|
| Hydraulics do not function.                               | Skid steer hydraulics not engaged.   | Engage skid steer hydraulics.                           |
|   | Hydraulic couplers not fully seated. | Check hydraulic couplers.                               |
|   | Low oil level.                       | Check skid steer hydraulic oil level. Add if necessary. |
| Lower frame lifting off ground during operation.          | Too much down pressure.              | Adjust down pressure in Maintenance Section.            |
| Hammer not staying in contact with post during operation. | Not enough down pressure.            | Adjust down pressure in Maintenance Section.            |



## 9. Warranty

Rhino Tool Company warrants the original purchaser, purchasing the equipment in new condition, that the Rhino Skid Steer Attachment will be free from defects in workmanship and materials, for a period of one (1) year. This warranty is non-transferable, and does not include the Furukawa Hydraulic Hammer, which is backed by Furukawa's Limited Warranty.

This Limited Warranty does not cover damage resulting from improper use, improper maintenance, or lack of maintenance/neglect, nor standard wear items (hydraulic hoses, etc.) from normal wear. Additionally, the Warranty does not extend to any product which has been subject to accident, nor does it extend to a unit that has been repaired, altered, or serviced by unauthorized persons. This Limited Warranty does not cover any damage or adjustments required, if such damage or adjustment is caused by the use of supplies, parts, or attachments not sold or approved by Rhino Tool.

EXCEPT AS OTHERWISE PROVIDED HERIN, RHINO TOOL DISCLAIMS ALL OTHER WARRANTIES, EXPRESSED OR IMPLIED, INCLUDING, BUT NOT LIMITED TO THE IMPLIED WARRANTIES OF MERCHANTABILITY AND FITNESS FOR A PARTICULAR PURPOSE. UNDER NO CIRCUMSTANCES SHALL RHINO TOOL BE LIABLE FOR ANY LOSS OF BUSINESS, REVENUES, OR PROFIT OR OTHER INDIRECT, INCIDENTAL, SPECIAL OR CONSEQUENTIAL DAMAGE OR LOSS ARISING OUT OF ANY EFFECTS IN OR PERFORMANCE OF THE PILE DRIVER ATTACHMENT, HOWEVER CAUSED.

# Parts

## 10. Parts

### 10.1 MAST

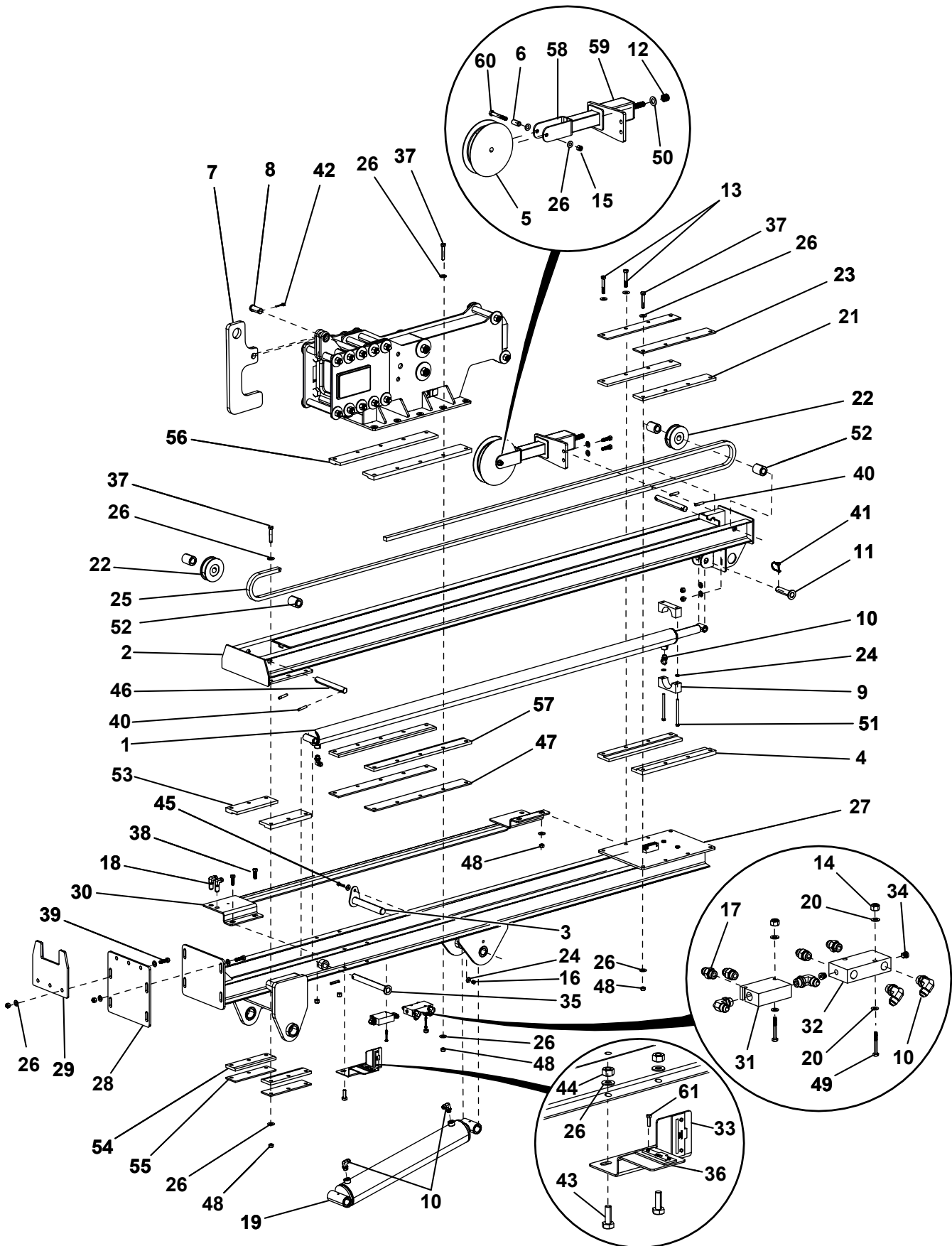

# Parts

| Item | Part Number | Description              | Qty |
|------|-------------|--------------------------|-----|
| 1    | 360191      | Cylinder, Mast Extension | 1   |
| 2    | 360079      | Frame Weldment           | 1   |
| 3    | 360096      | Pin                      | 1   |
| 4    | 360110      | Wear Slide - Notched     | 2   |
| 5    | 360167      | Pulley                   | 1   |
| 6    | 360168      | Bushing                  | 1   |
| 7    | 360174      | Plate - Puller           | 1   |
| 8    | 360175      | Pin                      | 1   |
| 9    | 360228      | Cylinder Mount           | 2   |
| 10   | 360233      | Hydraulic Fitting        | 8   |
| 11   | 360242      | Pin                      | 1   |
| 12   | 504011      | Lock Nut                 | 1   |
| 13   | 504019      | Hex Bolt                 | 2   |
| 14   | 518802      | Locknut                  | 4   |
| 15   | 518806      | Locknut                  | 1   |
| 16   | 504005      | Flat Washer              | 2   |
| 17   | 360234      | Hydraulic Fitting        | 4   |
| 18   | 360235      | Hydraulic Fitting        | 2   |
| 19   | 360194      | Cylinder                 | 1   |
| 20   | 504022      | Flat Washer              | 8   |
| 21   | 360111      | Wear Slide - Chamfered   | 2   |
| 22   | 360128      | Pulley                   | 2   |
| 23   | 360112      | Plate                    | 2   |
| 24   | 504005      | Flat Washer              | 2   |
| 25   | 360145      | Chain                    | 2   |
| 26   | 504000      | Flat Washer              | 62  |
| 27   | 360067      | Frame Weldment           | 1   |
| 28   | 360153      | Plate                    | 1   |
| 29   | 360154      | Plate                    | 1   |
| 30   | 360187      | Hose Guide Weldment      | 1   |
| 31   | 360201      | Valve                    | 1   |
| 32   | 360202      | Valve                    | 1   |
| 33   | 360253      | Level Bubble             | 2   |
| 34   | 360237      | Plug                     | 2   |
| 35   | 360243      | Pin                      | 1   |
| 36   | 360252      | Bracket                  | 1   |
| 37   | 504003      | Hex Bolt                 | 22  |
| 38   | 500178      | Hex Bolt                 | 2   |
| 39   | 500180      | Hex Bolt                 | 8   |
| 40   | 551302      | Spring Pin               | 5   |
| 41   | 995335      | Steel Pin With Wire Lock | 1   |
| 42   | 360244      | Pin                      | 1   |
| 43   | 500178      | Hex Bolt                 | 2   |
| 44   | 518806      | Hex Nut                  | 2   |
| 45   | 500010      | Hex Bolt                 | 1   |

# Parts

## MAST, CONTINUED

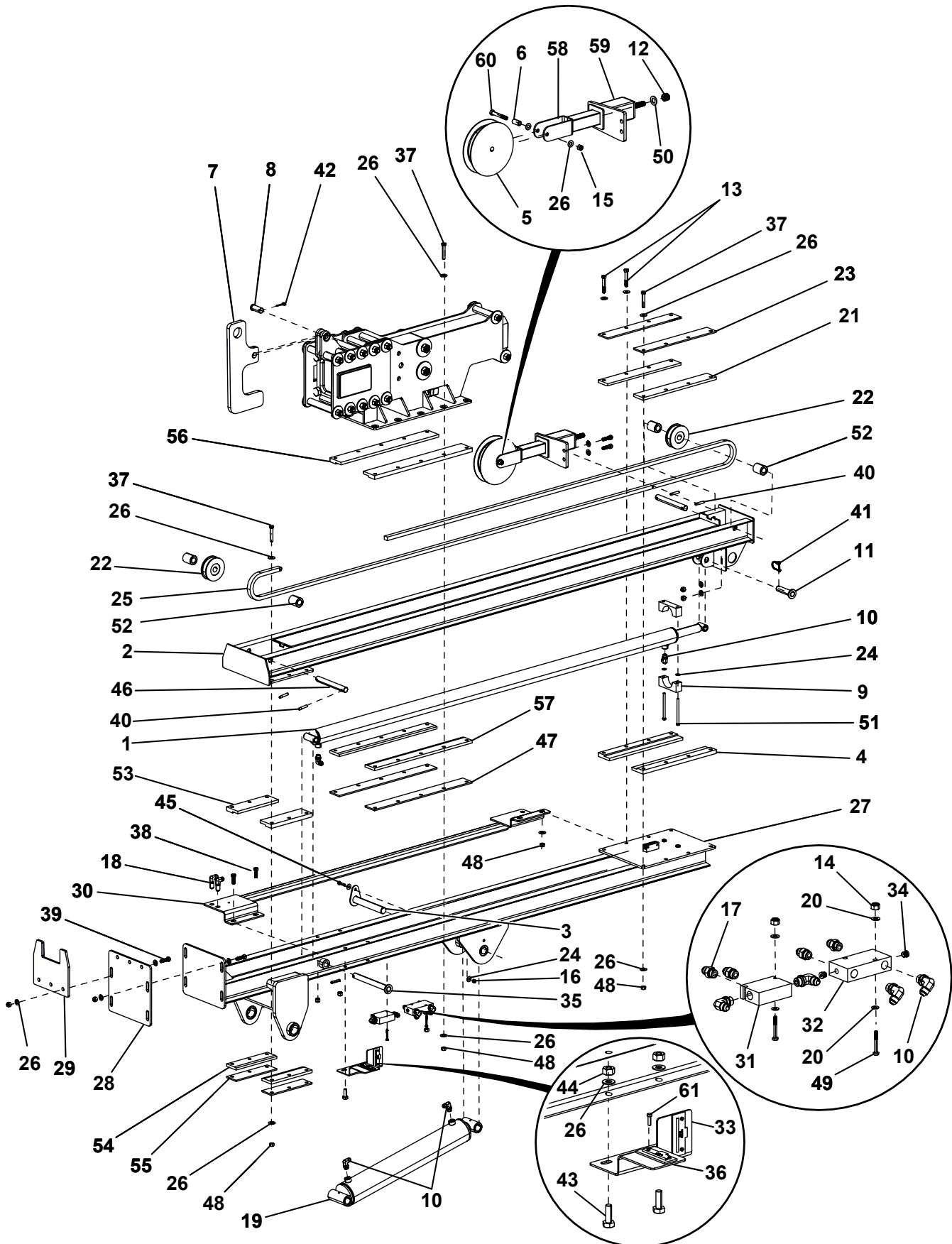

# Parts

| <b>Item</b> | <b>Part Number</b> | <b>Description</b>     | <b>Qty</b> |
|-------------|--------------------|------------------------|------------|
| 46          | 360092             | Pin                    | 2          |
| 47          | 360118             | Plate                  | 2          |
| 48          | 518806             | Hex Nut                | 22         |
| 49          | 504020             | Hex Bolt               | 4          |
| 50          | 504010             | Flat Washer            | 1          |
| 51          | 500014             | Hex Bolt               | 2          |
| 52          | 360127             | Bushing                | 4          |
| 53          | 360113             | Wear Slide - Notched   | 2          |
| 54          | 360114             | Wear Slide - Chamfered | 2          |
| 55          | 360115             | Plate                  | 2          |
| 56          | 360116             | Wear Slide - Notched   | 2          |
| 57          | 360117             | Wear Slide - Chamfered | 2          |
| 58          | 360161             | Weldment - Tensioner   | 1          |
| 59          | 360157             | Weldment - Tensioner   | 1          |
| 60          | 504021             | Hex Bolt               | 1          |
| 61          | 504025             | Screw                  | 4          |
|             |                    |                        |            |
|             |                    |                        |            |
|             |                    |                        |            |
|             |                    |                        |            |
|             |                    |                        |            |
|             |                    |                        |            |
|             |                    |                        |            |
|             |                    |                        |            |
|             |                    |                        |            |
|             |                    |                        |            |
|             |                    |                        |            |
|             |                    |                        |            |
|             |                    |                        |            |
|             |                    |                        |            |
|             |                    |                        |            |
|             |                    |                        |            |
|             |                    |                        |            |

# Parts

## 10.2 CENTER SECTION

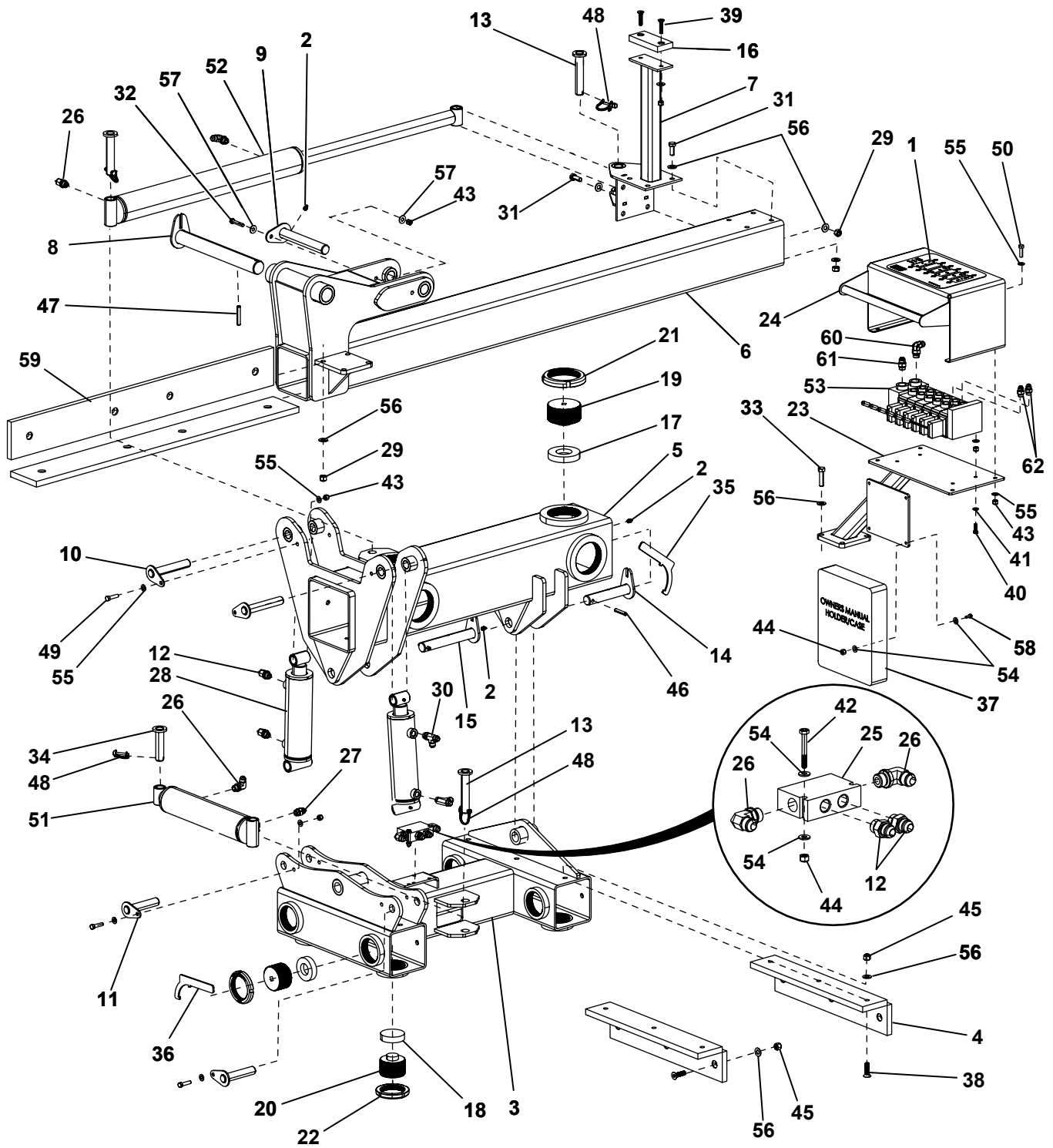

# Parts

| Item | Part Number | Description                  | Qty |
|------|-------------|------------------------------|-----|
| 1    | 000600      | Decal                        | 1   |
| 2    | 504023      | Grease Fitting               | 3   |
| 3    | 360032      | Frame Weldment               | 1   |
| 4    | 360040      | Wear Slide                   | 4   |
| 5    | 360050      | Frame Weldment               | 1   |
| 6    | 360052      | Frame Weldment               | 1   |
| 7    | 360060      | Stop Weldment                | 1   |
| 8    | 360093      | Pin                          | 1   |
| 9    | 360096      | Pin                          | 1   |
| 10   | 360099      | Pin                          | 2   |
| 11   | 360102      | Pin                          | 2   |
| 12   | 360234      | Hydraulic Fitting            | 2   |
| 13   | 360241      | Pin                          | 3   |
| 14   | 360104      | Pin                          | 1   |
| 15   | 360107      | Pin                          | 1   |
| 16   | 360109      | Wear Pad                     | 1   |
| 17   | 360119      | Wear Puck                    | 4   |
| 18   | 360120      | Wear Puck                    | 8   |
| 19   | 360121      | Adjusting Shaft              | 4   |
| 20   | 360122      | Adjusting Shaft              | 8   |
| 21   | 360123      | Nut - Locking                | 4   |
| 22   | 360124      | Nut - Locking                | 8   |
| 23   | 360147      | Weldment - Control Box Mount | 1   |
| 24   | 360190      | Weldment - Control Box       | 1   |
| 25   | 360203      | Valve                        | 1   |
| 26   | 360233      | Hydraulic Fitting            | 7   |
| 27   | 360234      | Hydraulic Fitting            | 1   |
| 28   | 360195      | Cylinder                     | 2   |
| 29   | 518806      | Hex Nut                      | 8   |
| 30   | 360238      | Hydraulic Fitting            | 2   |
| 31   | 500007      | Hex Bolt                     | 8   |
| 32   | 504001      | Hex Bolt                     | 1   |
| 33   | 500029      | Hex Bolt                     | 4   |
| 34   | 360242      | Pin                          | 1   |
| 35   | 360254      | Spanner Wrench               | 1   |
| 36   | 360255      | Spanner Wrench               | 1   |
| 37   | 360257      | Manual Storage Case          | 1   |
| 38   | 504004      | Hex Bolt                     | 11  |
| 39   | 504006      | Screw                        | 2   |
| 40   | 504017      | Hex Bolt                     | 4   |
| 41   | 504018      | Flat Washer                  | 4   |
| 42   | 504020      | Hex Bolt                     | 1   |
| 43   | 518801      | Lock Nut                     | 10  |
| 44   | 518802      | Lock Nut                     | 1   |

# Parts

## CENTER SECTION, CONTINUED

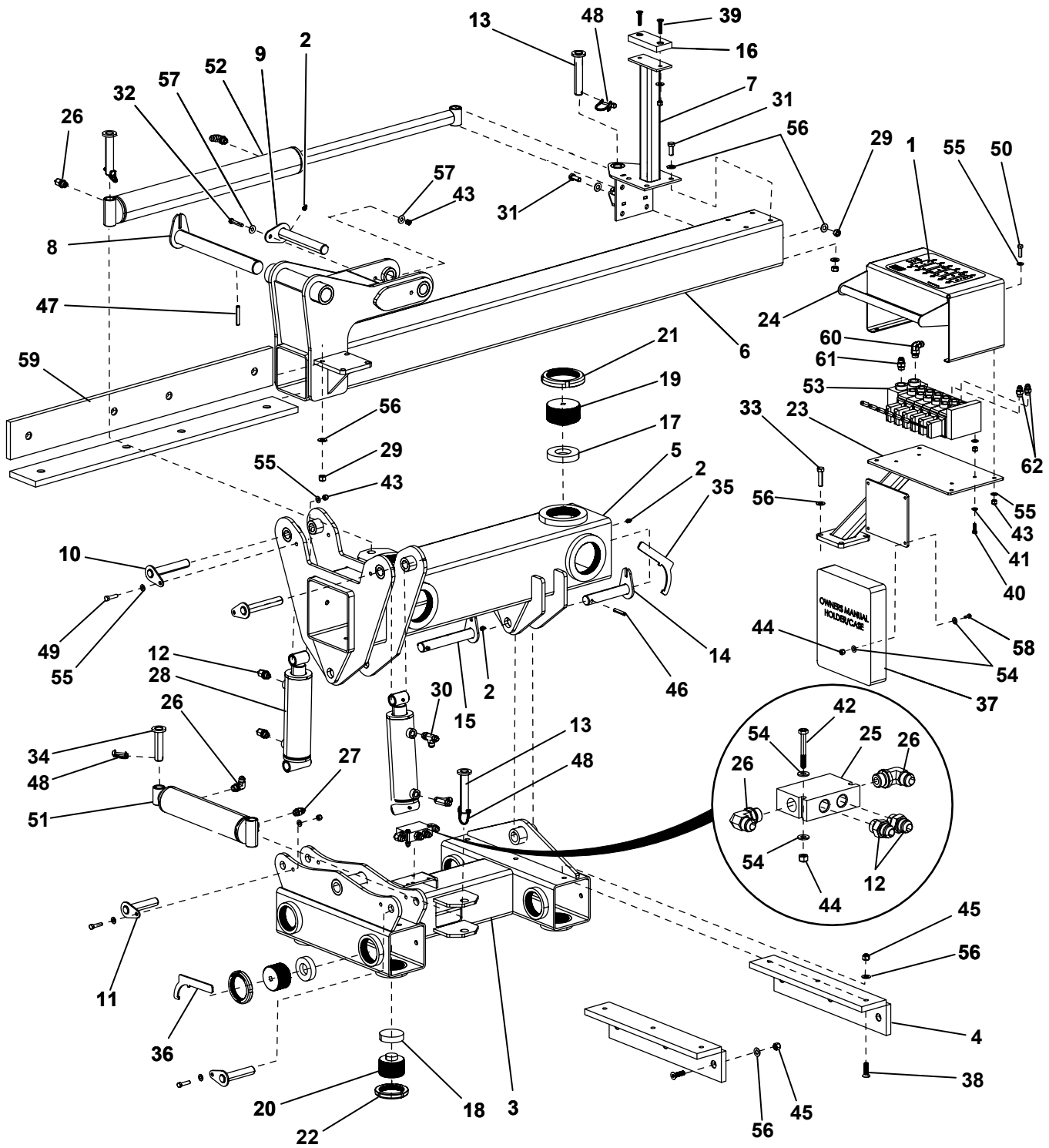



# Parts

| <b>Item</b> | <b>Part Number</b> | <b>Description</b>                   | <b>Qty</b> |
|-------------|--------------------|--------------------------------------|------------|
| 45          | 518806             | Lock Nut                             | 15         |
| 46          | 551302             | Spring Pin                           | 2          |
| 47          | 551303             | Spring Pin                           | 1          |
| 48          | 995335             | Zinc-Plated Steel Pin With Wire Lock | 4          |
| 49          | 500178             | Hex Bolt                             | 4          |
| 50          | 500082             | Hex Bolt                             | 4          |
| 51          | 360192             | Cylinder                             | 1          |
| 52          | 360193             | Cylinder                             | 1          |
| 53          | 360206             | Control Valve                        | 1          |
| 54          | 504022             | Flat Washer                          | 2          |
| 55          | 504005             | Flat Washer                          | 16         |
| 56          | 504000             | Flat Washer                          | 35         |
| 57          | 504005             | Flat Washer                          | 3          |
| 58          | 500001             | Hex Bolt                             | 4          |
| 59          | 360051             | Wear Slide                           | 2          |
| 60          | 306232             | Elbow Fitting                        | 1          |
| 61          | 306230             | Hydraulic Fitting                    | 1          |
| 62          | 360231             | Hydraulic Fitting                    | 12         |
|             |                    |                                      |            |
|             |                    |                                      |            |
|             |                    |                                      |            |
|             |                    |                                      |            |
|             |                    |                                      |            |
|             |                    |                                      |            |
|             |                    |                                      |            |
|             |                    |                                      |            |
|             |                    |                                      |            |
|             |                    |                                      |            |
|             |                    |                                      |            |
|             |                    |                                      |            |
|             |                    |                                      |            |
|             |                    |                                      |            |
|             |                    |                                      |            |
|             |                    |                                      |            |
|             |                    |                                      |            |
|             |                    |                                      |            |
|             |                    |                                      |            |
|             |                    |                                      |            |
|             |                    |                                      |            |
|             |                    |                                      |            |
|             |                    |                                      |            |
|             |                    |                                      |            |
|             |                    |                                      |            |
|             |                    |                                      |            |
|             |                    |                                      |            |
|             |                    |                                      |            |
|             |                    |                                      |            |
|             |                    |                                      |            |
|             |                    |                                      |            |

## 10.3 LOWER FRAME

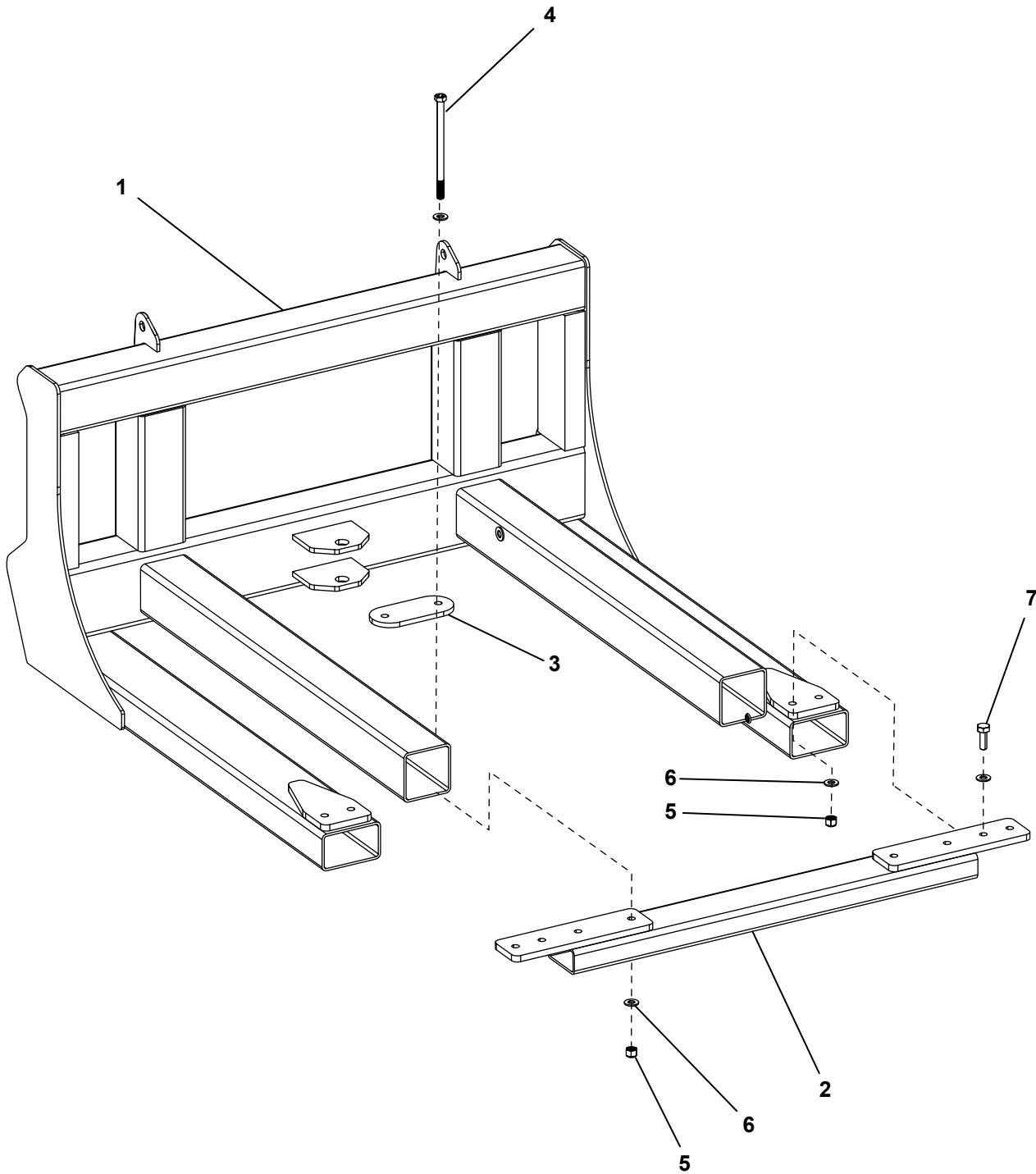



## 10.4 HYDRAULIC HOSES AND FITTINGS

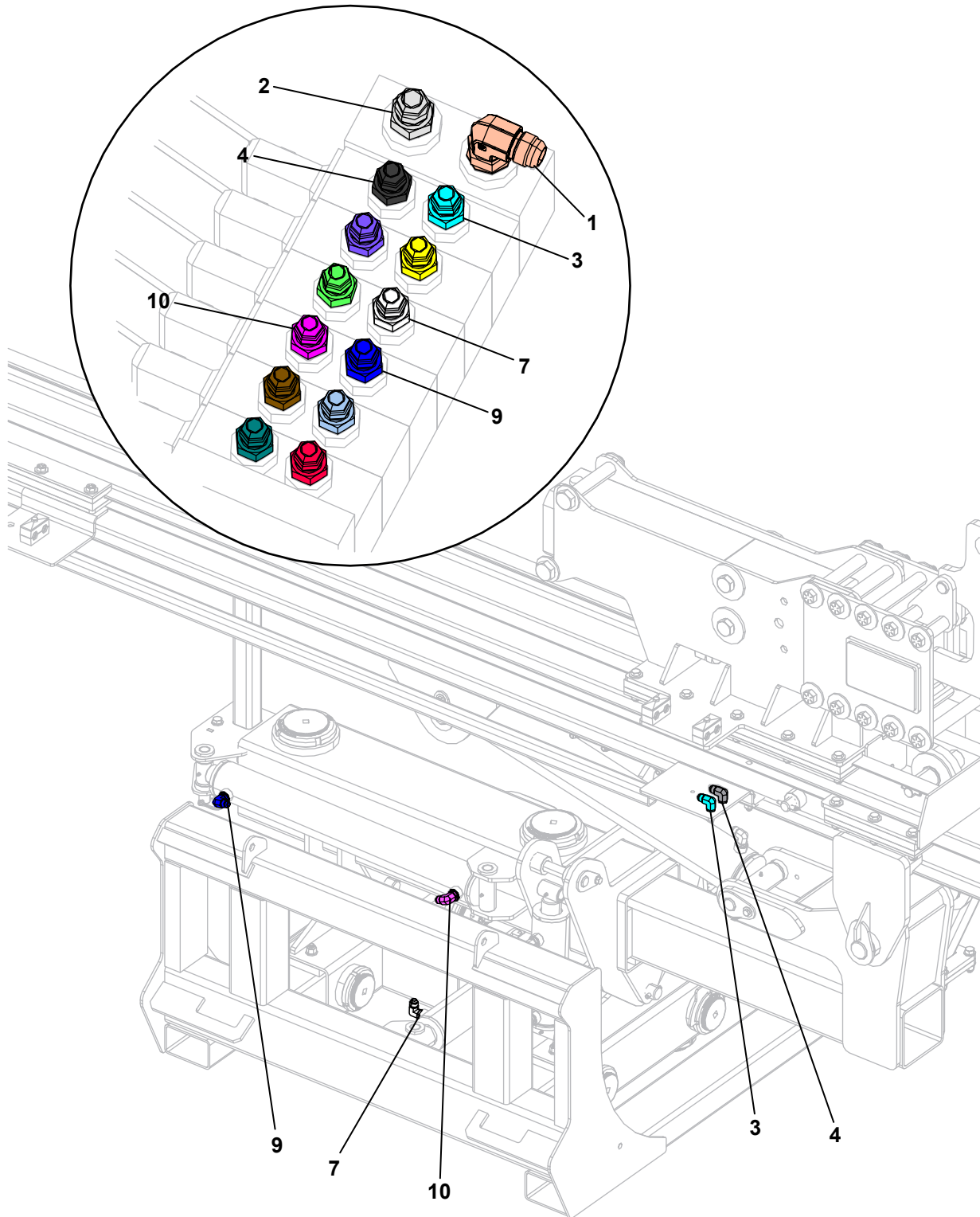

**Note:** Item numbers are referring to hose assembly to and from connecting points.



## HYDRAULIC HOSES AND FITTINGS, CONTINUED

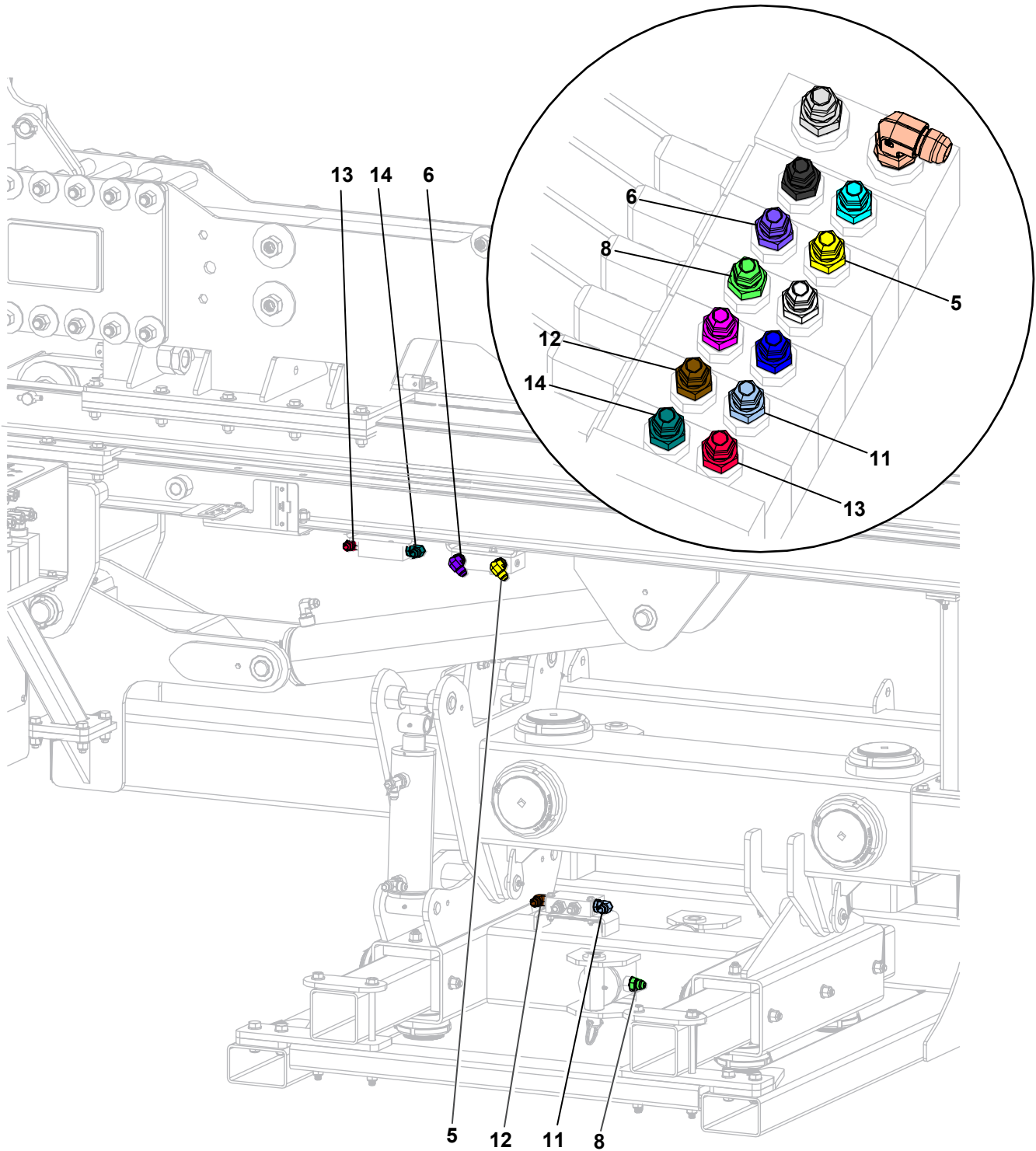

**Note:** Item numbers are referring to hose assembly to and from connecting points.



## HYDRAULIC HOSES AND FITTINGS, CONTINUED

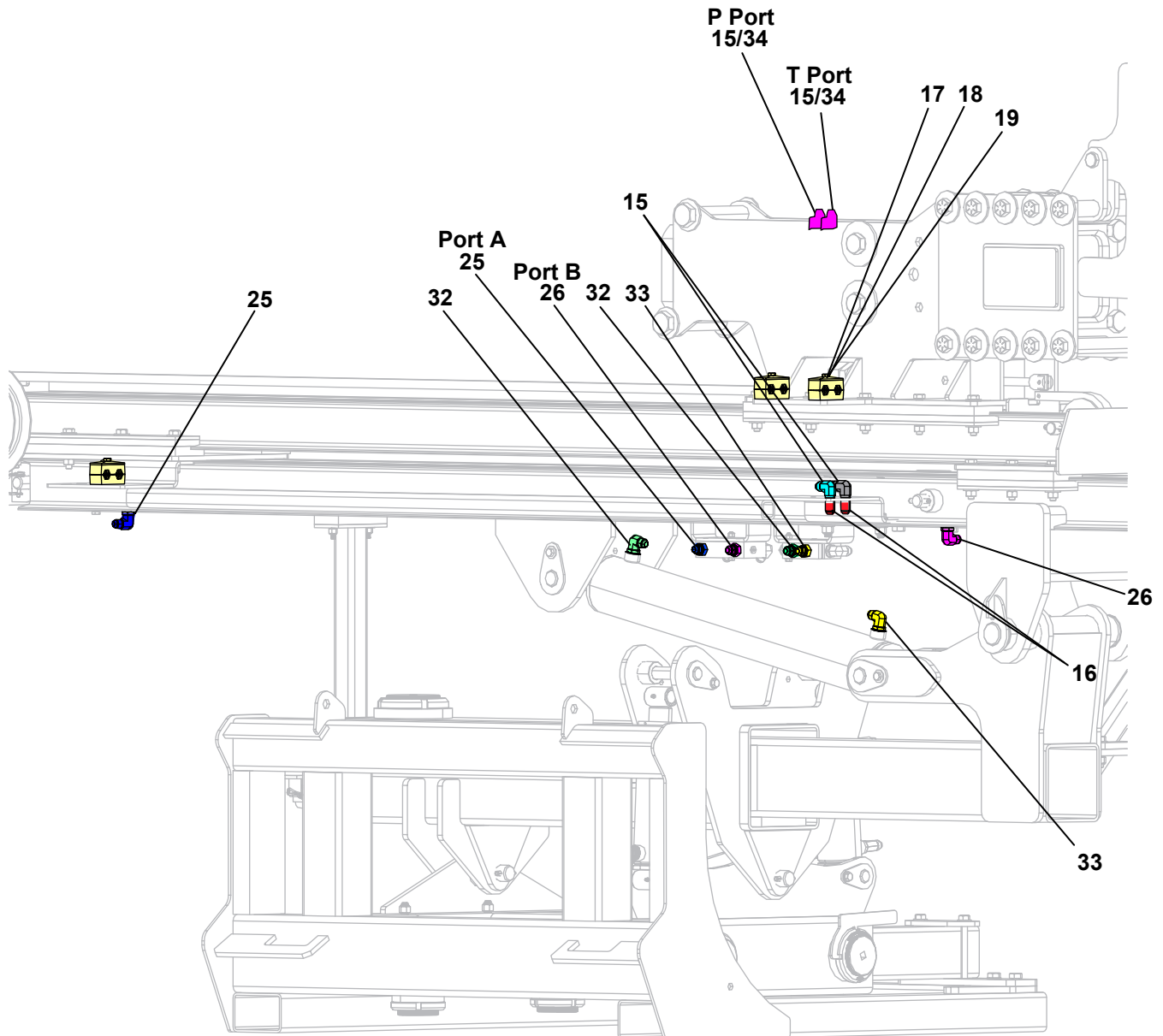

**Note:** Item numbers are referring to hose assembly to and from connecting points.





## HYDRAULIC HOSES AND FITTINGS, CONTINUED

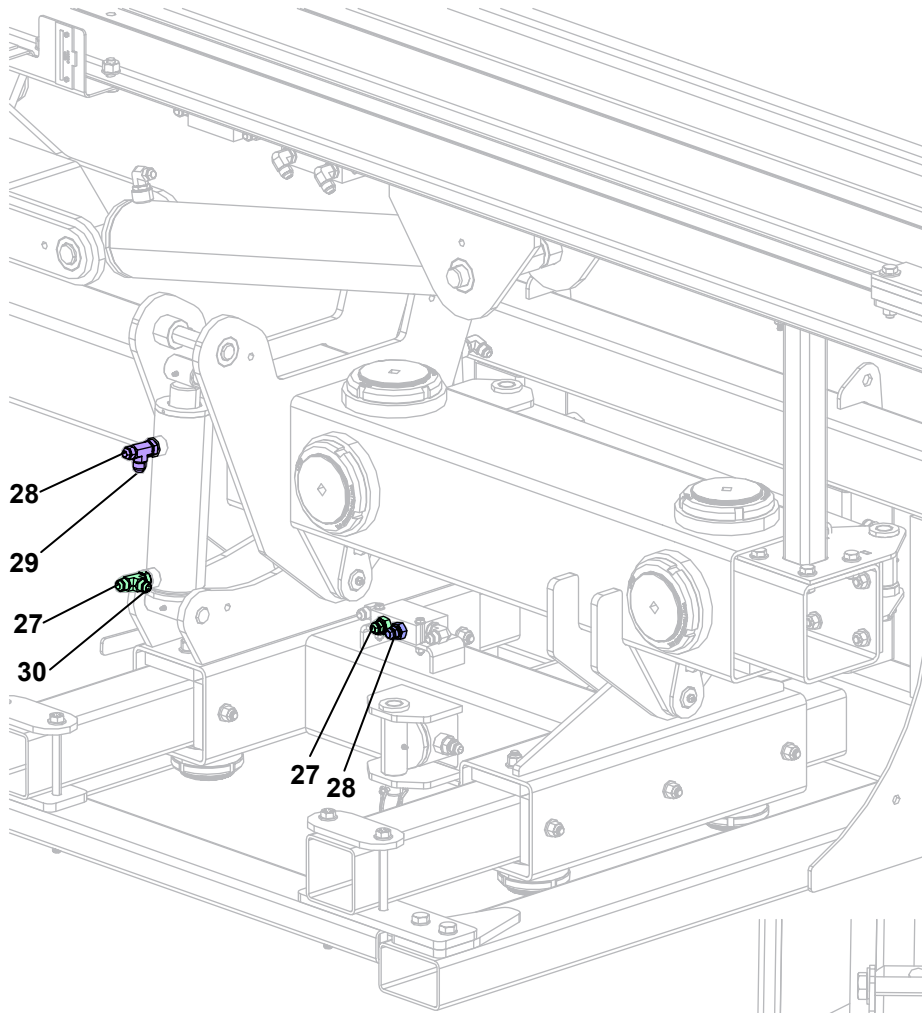

Side View

**Note:** Item numbers are referring to hose assembly to and from connecting points.

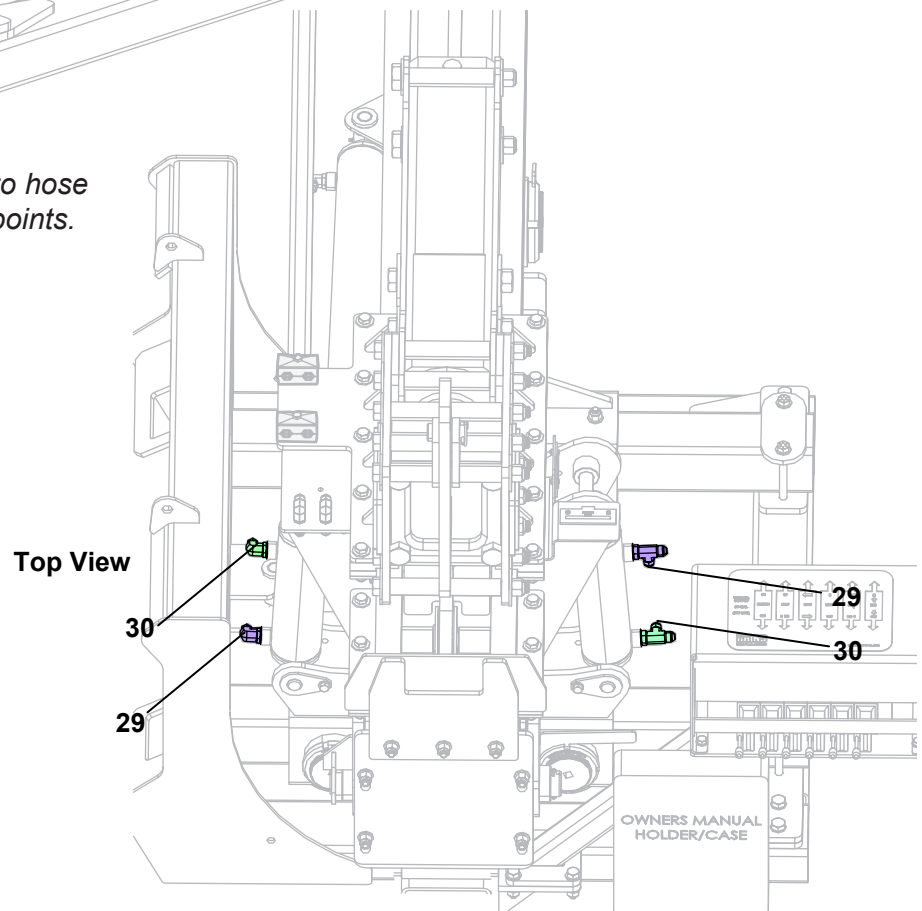

Top View





**Rhino Tool Company**  
**1134 West South Street**  
**PO Box 111**  
**Kewanee, IL 61443**  
**309-853-5555**  
**[www.rhinotool.com](http://www.rhinotool.com)**

Revision: February 2021