

PD-55 Postmaster Driver

PD-55 Pneumatic Post Driver for Postmaster Posts
Part No. 070019



Pneumatic • Hydraulic • Gasoline
Professional Grade Tools

For professional fence installers using the Master Halco® Postmaster and Postmaster Plus® Fence Systems, and similar types of post systems.

Installed with PD-55 Postmaster Chuck and Adapter to drive both Original Postmaster Post and Postmaster Plus Post types.

Other PD-55 bolt-in adapters can be used with the Postmaster Chuck – just remove the special Postmaster adapter and replace with another PD-55 adapter.
 Other adapters Sold Separately.

For more information on Postmaster posts, visit masterhalco.com

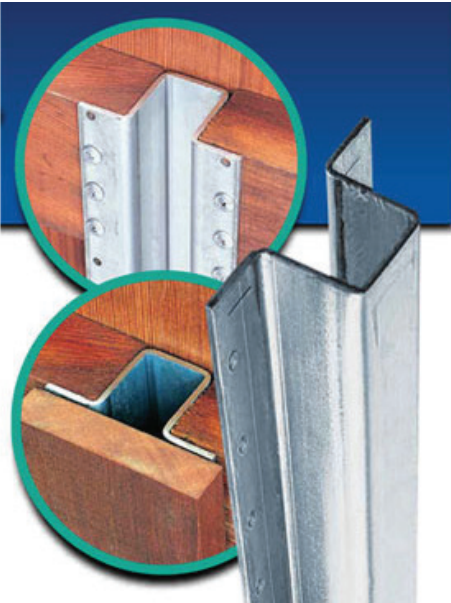
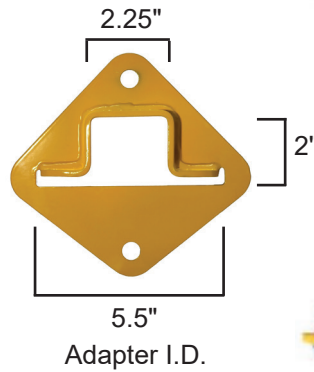
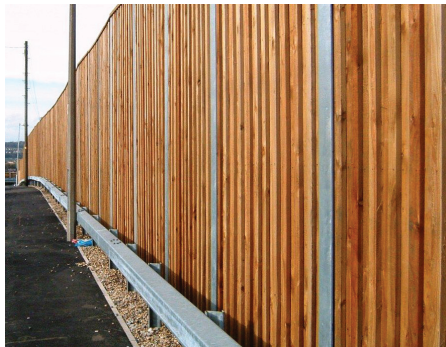

Part No.	Description and Parts Included
070019	PD-55 PostMaster® Post Driver

Specifications	PD-55 PostMaster® Driver
Wt. lb (kg)	74 (34)
Ship Wt. lb (kg)	80 (36)
Ship Dimensions (LxWxH)	24" x 12" x 10"

A Tradition of Quality and Service Since 1975



www.rhinotool.com
 866-707-1808