



PD-45/PD-55™

AIR-OPERATED POST DRIVER OWNERS MANUAL

MODEL: 070012, 070013



TAKE SAFETY SERIOUSLY

This book contains important safety information.
Please read it carefully.



Your safety, and the safety of others, is very important. The proper and safe use of your Rhino® post driver is an important responsibility and should be taken seriously.

Keep this owner's manual available, so you can refer to it at any time. This owner's manual is considered a permanent part of the post driver and should remain with the post driver if resold.

The information and specifications included in this publication were in effect at the time of approval for printing. Rhino Tool Company, Inc. reserves the right, however, to discontinue or change specifications or design at any time without notice and without incurring any obligation whatever. No part of this publication may be reproduced without written permission from:

Rhino Tool Company

To help you make informed decisions about safety, you will find important safety information in a variety of forms, including:

- Safety Labels on the post driver
- Safety Messages Preceded by a safety alert symbol and one of three signal words, DANGER, WARNING, or CAUTION. These signal words mean:



Immediate hazards that will result in severe personal injury or death.



Hazards or unsafe practices that could result in personal injury.



Hazards or unsafe practices that could result in injury, product or property damage.

- Safety Headings such as IMPORTANT SAFETY INFORMATION.
- Safety Section such as POST DRIVER SAFETY.
- Instructions how to use this post driver correctly and safely.



Rhino® PD-55 Driver Parts List

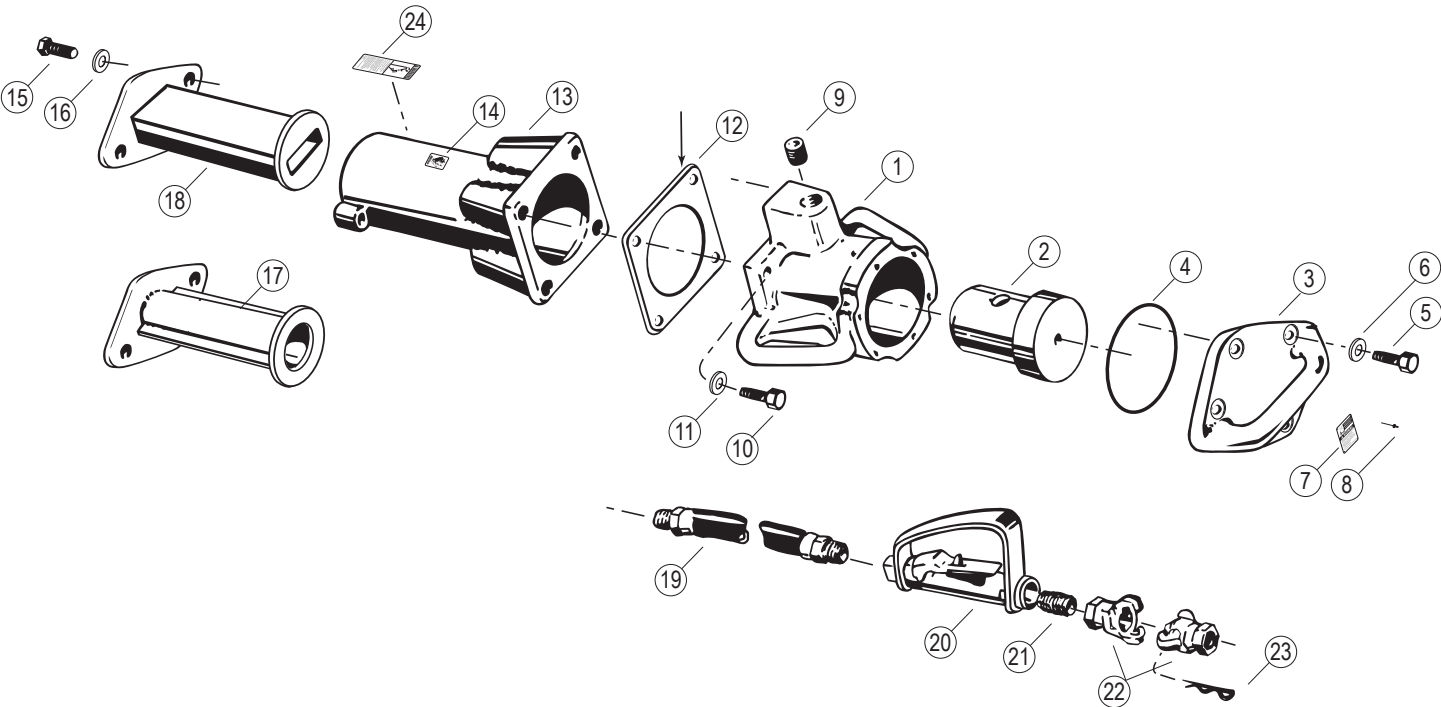

Rhino® PD-55 Driver Parts List

Number	Part No.	Name	Number	Part No.	Name
	070013	Model PD-55 with 3-7/8" (98.4.2 mm) I.D. Master Chuck	15	500178	Cap Screw (2 w/optional adapter)
1	070580	Body	16	517702	Compression Washer (2 per driver) w/adapter
2	070034	Piston	17	070609	3 1/2" (88.9 mm) I.D. Chuck Adapter**
3	070581	Top Cover	18	070617	Channel Post Chuck Adapter**
4	499401	O-ring		600000	Throttle Valve Kit w/ 5 ft. Hose Assembly ***
5	500021	Cap Screw (6 per driver)	19	607000	3/4" (19 mm) Hose Assembly
6	517705	Compression Washer (6 per driver)	19	605006	3/4" (19 mm) Hose Per Foot (Order Length Needed)
7	000235	Model/Serial No./Warning Plate	20	610026	Throttle Valve with Lever Guard
8	519004	Metal Tack (4 per driver)	21	610024	Screen Fitting
9	230400	Pipe Plug	22	606600	Coupler (2 per driver)
10	500178	Cap Screw (4 per driver)	23	606601	Safety Clip
11	517702	Compression Washer (4 per driver)	24	000244	Warning Label
12	700001	Gasket			* Includes number 10, 11, 12, 13, 14, 24
13	070592	3" (76.2 mm) I.D. Master Chuck Assembly*			** See page 4 for specifying Chuck Adapter to your application
14	000135	Rhino Decal			*** Includes number 19, 20, 21, 22, 23

Symptom	Explanation/Procedure
Post lodged in the driver	<ol style="list-style-type: none"> 1. Remove the 2 bolts that secure the adapter and separate the driver from the adapter. 2. Slide the adapter down the post to expose the top of the post. With the proper cutting tool for the type of post, cut through the post below the flared portion. 3. Once the deformed portion is removed, slide the adapter off the post and reassemble it to the driver. Please follow bolt tightening procedure.
Drives post slow or sluggish performance	<ol style="list-style-type: none"> 1. Inspect the chuck to see if there is any foreign material blocking the piston. 2. Check to see if piston is moving freely by disconnecting the driver from air, tipping upside down and back upright. You should be able to hear the piston moving freely. 3. Check to ensure the rate of lubrication is adequate. 4. If using a FRL, inspect the filter on the FRL, if impacted with residue replace with new filter. 5. Inspect the filter on the Throttle. If clogged, blow off debris with air hose, or clean with a common cleaning solvent. 6. Check to see if air pressure is correct 7. Check output on compressor 8. In temperatures under 40°F (4°C) or high humidity conditions check air lines and tool for icing.
Noticeable air passing through driver or “blow by”	<p>To confirm this condition exists, connected to air source, place driver on a post, while activating the throttle lift the driver slightly if the piston increases in activity blow by is confirmed. This indicates there is most likely damaged or worn parts inside the driver. In this event the driver should be sent to Rhino Tool Company to be inspected and we will report if the driver is repairable.</p>
Other problems or technical questions	<p>Other problems or technical questions: Document your serial number and contact Rhino Tool Company. Phone: 309.853.5555 or Toll Free 866-707-1808, Fax:309.856.5905, Email: service@rhinotool.com. In Europe contact Eurogate Int. F: (0031) (0) 523 638286, M: (0031) (0) 610 502607.</p>



A TRADITION OF QUALITY AND SERVICE SINCE 1975

WWW.RHINOTOOL.COM

Form 000302-09/2017

Rhino Tool Company, Inc. | P.O. Box 111 | Kewanee, IL 61443 | 309.853.5555 | 866-707-1808